



**Refrigerated Air Dryer
for High Temp.
Water Cooled Type**

Rev.	Date	Prepared By	Checked By	Approved By
A	2020.09.23	WOO.I.H.	JO.S.J.	KIM.H.W.
B				
C				
D				

Project Name	-	Model Name	HYD-900HTW
--------------	---	------------	------------

SPECIFICATION				
1				
2	Supply Voltage	380V	Inlet Flow Rate	140 Nm3/min
3	Phase	3PH	Inlet Pressure	7 barg
4	Frequency	60Hz	Inlet Temperature	38 °C
5	Control use	220V	Outlet Flow Rate	140 Nm3/min
6	Fulid	Compressed Air	Outlet Pressure	6.8 barg
7	Location	Indoor	Outlet Temperature	28±5 °C
8	Design Code	Maker STD.	Pressure Drop	0.2 bar
9	Area Class	Non-Hazardous	Outlet Dew Point	2~10 °C@PDP
10	Cooling Water Capacity	302 L/min	Design Pressure	9.7 barg
11	Cooling Water Pressure	2 ~ 3 barg	Design Temperature	70 °C
12	Cooling Water Temperature	32 °C	Ambient Temperature	32 °C
CONSTRUCTION				
13				
14	Refrigerant	R-22	Dimension (W x L x H)	1,500 X 2,100 X 2,150 mm
15	Ref. Compressor Type	Scroll	Weight	1,320 kg
16	Ref. Compressor Capacity	30 HP	Power Consumption	27.9 kW
17	Condenser Type	Water Cooled	Inlet Connection	200A KS 10K SO.FF.
18	Condenser Capacity	30 HP	Outlet Connection	200A KS 10K SO.FF.
19	Heat Exchanger Type	Block	Cooling Water Connection	50A PT Union
20	Heat Exchanger Material	Aluminum	Drain Connection	15A PT Female Screw
21	Ref. Control Device	TEV	Color (Munsell)	5.7PB 4.1/9.9
22	Temp. Control Device	Hot Gas Bypass Valve		5.7PB 2.9/3.5
23	Drain Trap Type	Level Sensor		
STANDRAD FEATURES AND CONTROL				
24				
25	Ref. Compressor	YES	Auto Drain	YES
26	Water Cooled Condenser	YES	Hot Gas Bypass Valve	YES
27	Cooling Water Regulating Valve	YES	Suction Line Accumulator	YES
28	Liquid Ref. Receiver	YES	Oil Separator	YES
29	Filter Dryer	YES	Ref. Pressure Switch	NO
30	Expansion Valve	YES	4.3" TFT LCD	YES
31	Heat Exchanger	YES	PCB Controller	YES
32	Ref. Pressure Transmitter	YES		
33	Air Pressure Gauge	YES		
34	Ref. Pressure Gauge	YES		
NOTES				
35				
36				
37				
38				
39				
40				
41				
42				
43				
44				
45				
46				

10 T0-MLH0060-QH-YSD
ON SWG

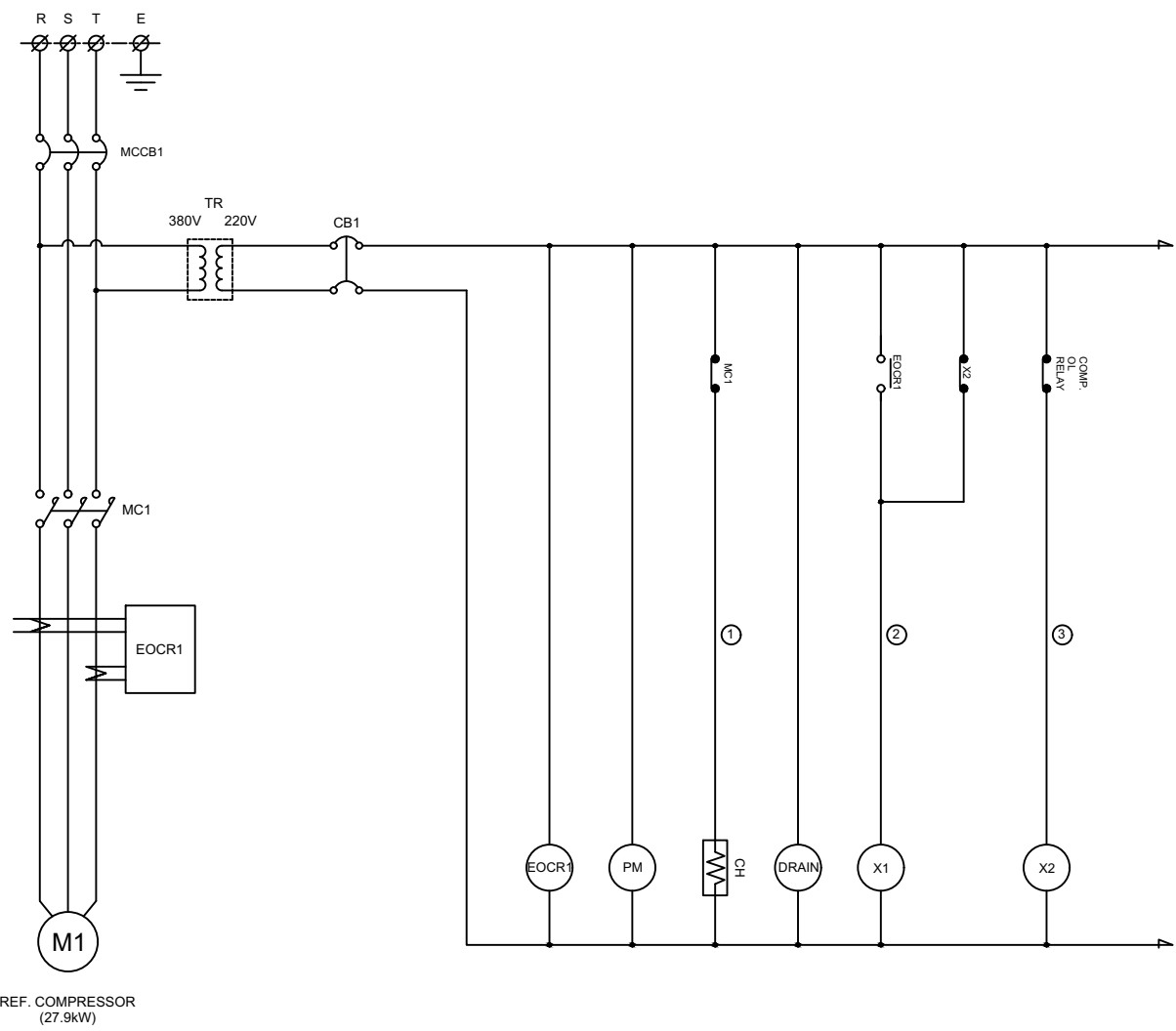

POWER SOURCE AC 380/440V, 3Ph, 50/60Hz		
12	PT1	REF. PRESSURE TRANSMITTER
11	TS1 ~ TS4	TEMP. SENSOR
10	X1, X2	RELAY
9	DRAIN	CONDENSATE WATER DRAIN
8	CH	REF. COMP. HEATER
7	PM	REF. COMP. PROTECTION MODULE
6	CB1	CIRCUIT BREAKER
5	TR	TRANSFORMER
4	EOCR1	REF. COMP. OVERLOAD RELAY
3	MC1	REF. COMP. MAGNETIC CONTACTOR
2	MCCB1	MOLDED CASE CIRCUIT BREAKER
1	M1	REF. COMPRESSOR
NO.	SYMBOL	DESCRIPTION

***REVERSE PHASE WARNING**
Be sure to check the rotation direction of the fan motor and the operating condition of the refrigerant compressor.

- The fan motor must rotate clockwise.
- When the refrigerant compressor is operating, the refrigerant suction pressure will be lowered.

When operating in reverse phase, the refrigerant compressor is damaged.

In case of reverse phase, change the position of 2 wires out of 3 wires of the power supply line.

Problems caused by incorrect power connection are not guaranteed.

△									
△									
△									
△									
△									
△	2020. 09. 28	ISSUED FOR REFERENCE							
REV.	DATE	DESCRIPTION	ENG	CHK	APPO	APPO	APPO	APPO	APPO

PROJECT: -

MANUFACTURER: **GSA**
Global Standard Air & Gas

TITLE: **WIRING DRAWING**

ITEM NO.	HYD-900HTW	EWG NO.	GSA-HYD-0900HTW-03_01	REV.	
SCALE	NONE				

(A4 : 297mm x 210mm)

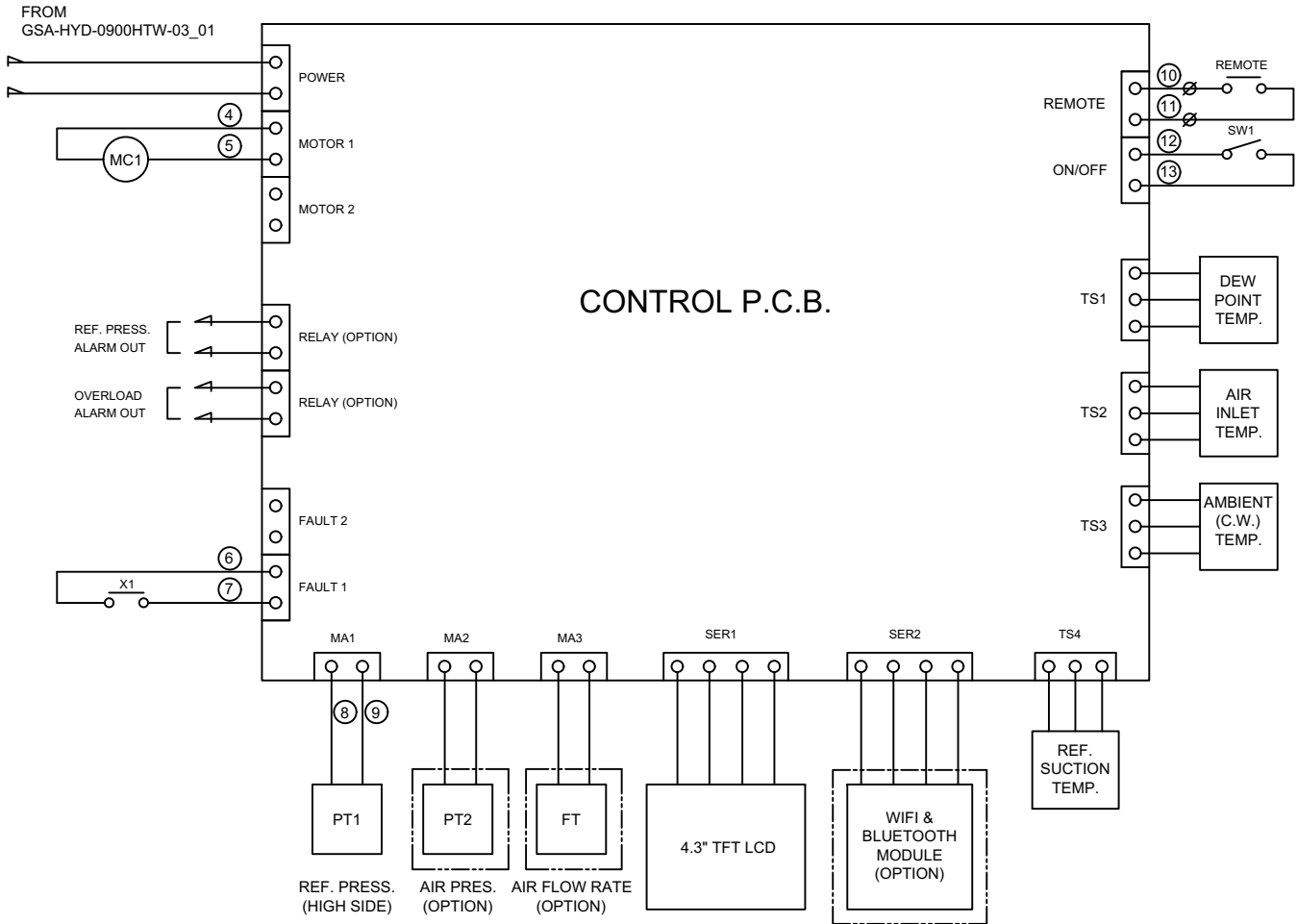

CONTROL P.C.B.

POWER SOURCE AC 380/440V, 3Ph, 50/60Hz		
12	PT1	REF. PRESSURE TRANSMITTER
11	TS1 ~ TS4	TEMP. SENSOR
10	X1, X2	RELAY
9	DRAIN	CONDENSATE WATER DRAIN
8	CH	REF. COMP. HEATER
7	PM	REF. COMP. PROTECTION MODULE
6	CB1	CIRCUIT BREAKER
5	TR	TRANSFORMER
4	EOCR1	REF. COMP. OVERLOAD RELAY
3	MC1	REF. COMP. MAGNETIC CONTACTOR
2	MCCB1	MOLDED CASE CIRCUIT BREAKER
1	M1	REF. COMPRESSOR
NO.	SYMBOL	DESCRIPTION

***REVERSE PHASE WARNING**

Be sure to check the rotation direction of the fan motor and the operating condition of the refrigerant compressor.

- The fan motor must rotate clockwise.
- When the refrigerant compressor is operating, the refrigerant suction pressure will be lowered.

When operating in reverse phase, the refrigerant compressor is damaged.

In case of reverse phase, change the position of 2 wires out of 3 wires of the power supply line.

Problems caused by incorrect power connection are not guaranteed.

△									
△									
△									
△									
△									
△	2020.09.28	ISSUED FOR REFERENCE							
REV. NO.	DATE	DESCRIPTION	DWG	CHK	APPD	APPD	APPD	APPD	APPD

PROJECT: -

MANUFACTURER: **GSA**
Global Service Air & Gas

TITLE: **WIRING DRAWING**

ITEM NO.	HYD-900HTW	DWG NO.	GSA-HYD-0900HTW-03_02	REV.	△
SCALE	NONE				