	<b>Eco Pro Refrigerated Air Dryer</b>		Rev.	Date	Prepared By	Checked By	Approved By
			1	2019.01.15	LEE.S.M.	JO.S.J.	KIM.H.W.
	<b>Air Cooled Type</b>		2				
			3				
4							
Project Name			-		Model Name		HYD-600N2
<b>SPECIFICATION</b>							
1							
2	Supply Voltage	380V	Inlet Flow Rate	85	Nm3/min		
3	Phase	3PH	Inlet Pressure	7	barg		
4	Frequency	60Hz	Inlet Temp.	38	°C		
5	Control use	220V	Outlet Flow Rate	85	Nm3/min		
6	Fulid	Compressed Air	Outlet Pressure	6.8	barg		
7	Location	Indoor	Outlet Temp.	28±5	°C		
8	Design Code	Maker STD.	Pressure Drop	0.2	bar		
9	Area Class	Non-Hazardous	Outlet Dew Point	2~10	°C		
10			Design Pressure	9.7	barg		
11			Design Temperature	70	°C		
12			Ambient Temperature	32	°C		
<b>CONSTRUCTION</b>							
13							
14	Refrigerant	R-22	Dimension (W x L x H)	1,200 X 1,800 X 1,825	mm		
15	Ref. Compressor Type	Scroll	Weight	1,100	kg		
16	Ref. Compressor Capacity	13 HP	Min. Power Consumption	6.35	kW		
17	Condenser Type	Air Cooled	Inlet Connection	150A	KS 10K SO.FF.		
18	Condenser Fan Motor	0.4 kW	Outlet Connection	150A	KS 10K SO.FF.		
19		2 EA	Drain Connection	15A	PT Female Screw		
20	Condenser Fan Size	600 mm	Color (Munsell)	5.7PB 4.1/9.9			
21	Condenser Capacity	15 HP		5.7PB 2.9/3.5			
22	Condenser Material	Aluminum & Copper					
23	Heat Exchanger Type	Block					
24	Heat Exchanger Material	Aluminum					
25	Ref. Control Device	TEV					
26	ECO Mode Control	Dew Point Temp. Control					
27	Drain Trap Type	Level Sensor					
<b>STANDRAD FEATURES AND CONTROL</b>							
28							
29	Ref. Pressure Transmitter	YES	Ref. Compressor	YES			
30	Ref. Liquid Filter Dryer	YES	Expansion Valve	YES			
31	Overload Relay	YES	Hot Gas Bypass Valve	YES			
32	PCB Controller	YES	Air Cooled Condenser	YES			
33	4.3" TFT LCD	YES	Accumulator with Heat Exchanger	YES			
34	Air Pressure Gauge	YES	Liquid Ref. Receiver	NO			
35	Ref. Pressure Gauge	YES	Oil Separator	YES			
36	Dual Pressure Switch	NO	Circuit Breaker	YES			
37	Moisture Indicator	YES	Ref. Compressor Heater	YES			
38	Drain	YES					
<b>NOTES</b>							
39							
40							
41							
42							
43							
44							
45							
46							

T0-N00090-GH-VSS  
CON DWG

AIR INLET  
150A KS 10K SO.FF.

AIR OUTLET  
150A KS 10K SO.FF.

COOLING AIR DIRECTION

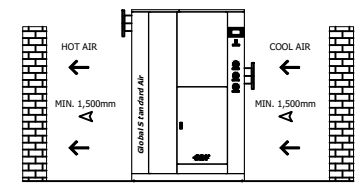

SPECIFICATION	
INLET AIR TEMPERATURE	38°C
AMBIENT TEMPERATURE	32°C
INLET AIR PRESSURE	7 barg
CAPACITY	85.0 Nm <sup>3</sup> /min
IN/OUT CONNECTION	150A KS 10K SO.FF.
DIMENSION(WXDXH, mm)	1,200 X 1,800 X 1,830
WEIGHT	1,100 kg
MIN POWER CONSUMP.	6.35 kW
POWER SUPPLY	380/440V - 3PH - 50/60Hz

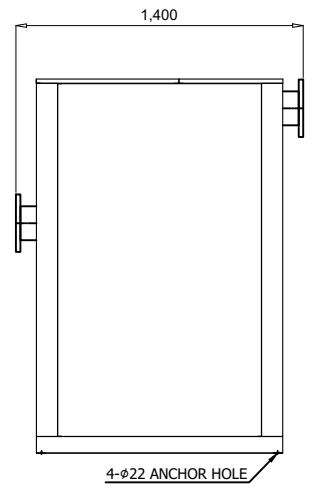
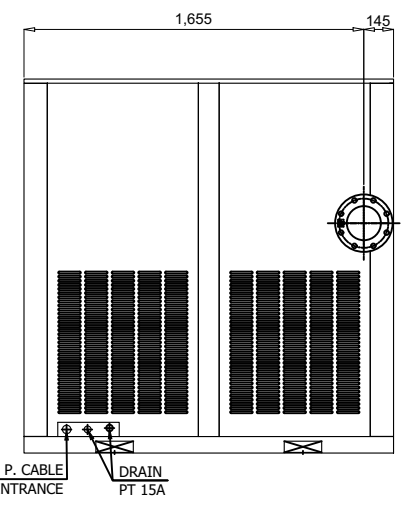
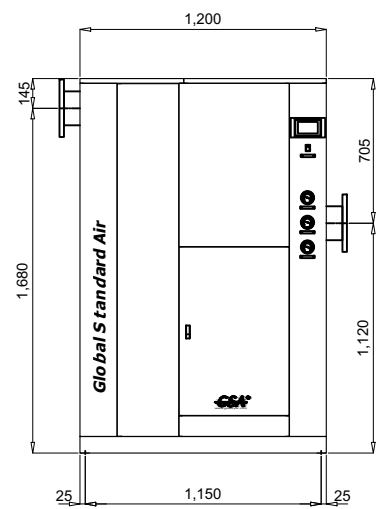
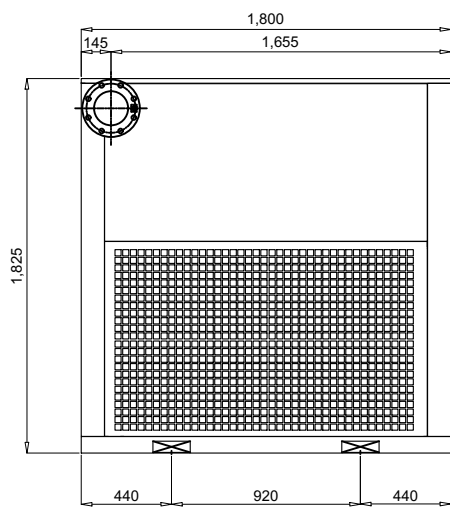

REV.	DATE	DESCRIPTION	DWG	CHK	APPD	APPD
2018.11.26		ISSUED FOR REFERENCE				
PROJECT						
MANUFACTURER						
<b>GSA</b> Global Standard Air & Gas						
TITLE						
OUTLINE DRAWING						
ITEM NO.	HYD-6002	DWG NO.	GSA-HYD-0600N2-01			
SCALE	NONE					

(A4 : 297mm x 210mm)

Z0-N0090-GJH-VSS  
ON DWG

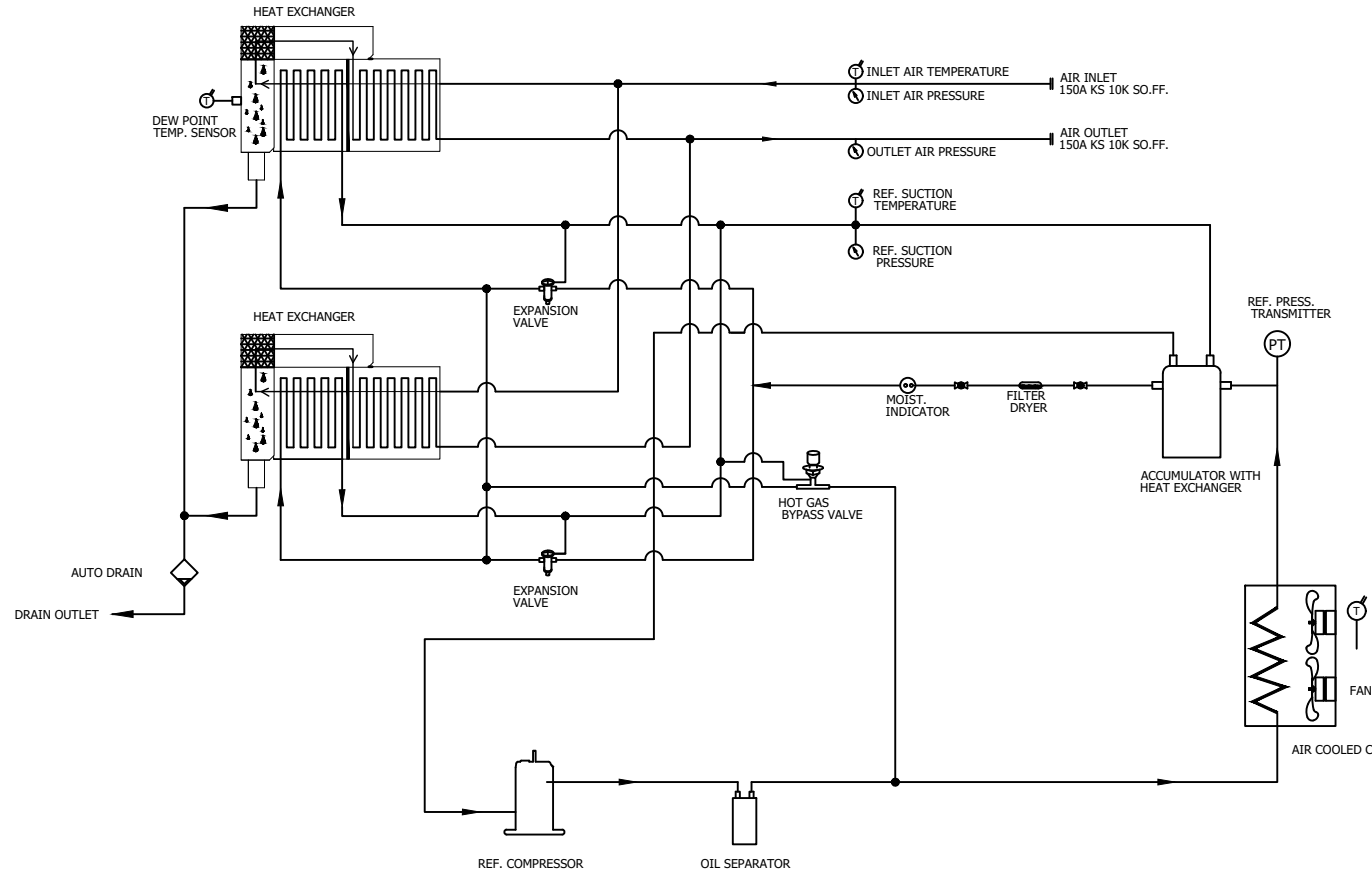

← AIR INLET LINE  
 → AIR OUTLET LINE  
 ← REF. LOW PRESS. LINE  
 → REF. HIGH PRESS. LINE

DEW POINT	2~10°C @ FDP		
INLET AIR PRESSURE	7.0 BARG		
INLET AIR TEMPERATURE	38°C		
CAPACITY	85.0 Nm <sup>3</sup> /min		
15	PRESS. GAUGE	OUTLET AIR	1
14	PRESS. GAUGE	INLET AIR	1
13	PRESS. GAUGE	REF. SUCTION	1
12	AUTO DRAIN	PT 15A	1
11	HGBV	-	1
10	HEAT EXCHANGER	300 HP	2
9	EXPANSION VALVE	7.5 TON	2
8	MOIST. INDICATOR	5/8"	1
7	FILTER DRYER	5/8"	1
6	ACCUMULATOR WITH HEAT EXCHANGER	-	1
5	REF. PRESS. TRANSMIT.	-1 ~ 35 BAR	1
4	FAN MOTOR	0.4KW 6P #600	2
3	A/C CONDENSER	15 HP (CONDENSING CAPACITY)	1
2	OIL SEPARATOR	-	1
1	REF. COMPRESSOR	13 HP (COOLING CAPACITY)	1
NO.	PART NAME	DESCRIPTION	QTY

△									
△									
△									
△									
△	2020. 09. 16.	PARTS NUMBER DELETE							
△	2018. 11. 26.	ISSUED FOR REFERENCE							
REV.	DATE	DESCRIPTION	ENG	CHK	APPD	APPD	APPD	APPD	APPD
PROJECT									
MANUFACTURER									
 <b>GSA</b> <small>Global Standard Air &amp; Gas</small>									
TITLE									
<b>PIPING &amp; INSTRUMENTATION DRAWING</b>									
ITEM NO.	HYD-6002	DWG NO.	GSA-HYD-0600N2-02						
SCALE	NONE								

(A4 : 297mm x 210mm)

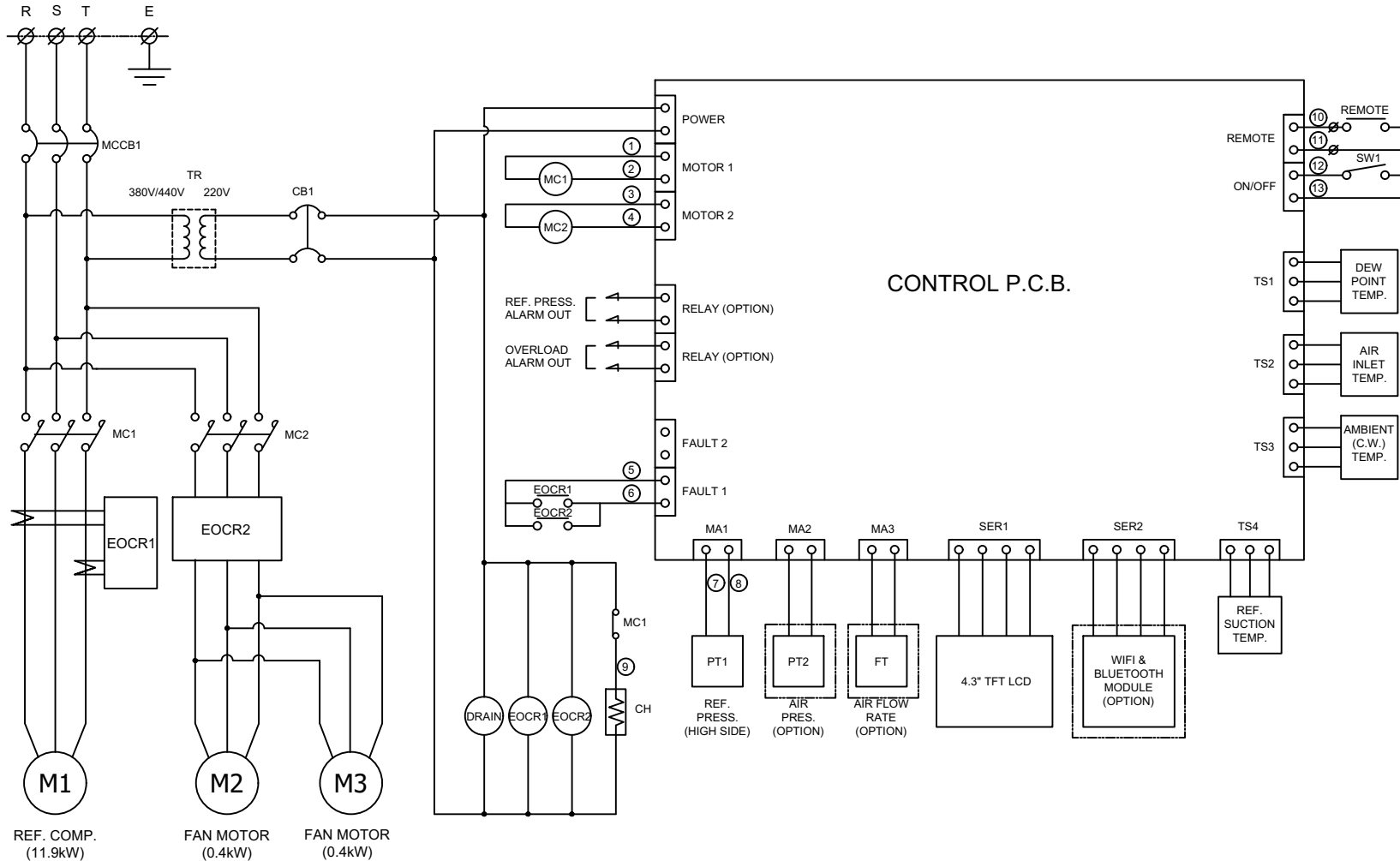

POWER SOURCE AC 380/440V, 3Ph, 50/60Hz		
12	PT1	REF. PRESSURE TRANSMITTER
11	DRAIN	AUTO DRAIN VALVE
10	SW1	SYSTEM ON/OFF SWITCH
9	CH	REF. COMP. HEATER
8	DRAIN	AUTO DRAIN VALVE
7	TS1 ~ TS4	TEMP. SENSOR
6	CB1	CIRCUIT BREAKER(CTRL)
5	MCCB1	CIRCUIT BREAKER(MAIN)
4	MC1, MC2	MAGNETIC CONTACTOR
3	EOCR1, EOCR2	OVERLOAD RELAY
2	M2, M3	FAN MOTOR
1	M1	REF. COMPRESSOR
NO.	SYMBOL	DESCRIPTION

**\*REVERSE PHASE WARNING**

Be sure to check the rotation direction of the fan motor and the operating condition of the refrigerant compressor.

- The fan motor must rotate clockwise.
- When the refrigerant compressor is operating, the refrigerant suction pressure will be lowered.

When operating in reverse phase, the refrigerant compressor is damaged.

In case of reverse phase, change the position of 2 wires out of 3 wires of the power supply line.

Problems caused by incorrect power connection are not guaranteed.

△									
△									
△									
△									
△	2018. 11. 26.	ISSUED FOR REFERENCE							
REV. NO.	DATE	DESCRIPTION	DWG	CHK	APPD	APPD	APPD	APPD	APPD

PROJECT: -

MANUFACTURER: **GSA**  
Global Service Automation & Control

TITLE: **WIRING DRAWING**

ITEM NO.	HYD-600N2	DWG NO.	GSA-HYD-0600N2-03	REV.	△
SCALE	NONE				