



**Refrigerated Air Dryer  
for High Temp.**

**Water Cooled Type**

Rev.	Date	Prepared By	Checked By	Approved By
A	2020.09.23	WOO.I.H.	JO.S.J.	KIM.H.W.
B				
C				
D				

Project Name	-	Model Name	HYD-600HTW
--------------	---	------------	------------

SPECIFICATION				
1				
2	Supply Voltage	380V	Inlet Flow Rate	85.0 Nm3/min
3	Phase	3PH	Inlet Pressure	7.0 barg
4	Frequency	60Hz	Inlet Temperature	45 °C
5	Control use	220V	Outlet Flow Rate	85.0 Nm3/min
6	Fulid	Compressed Air	Outlet Pressure	6.8 barg
7	Location	Indoor	Outlet Temperature	33±5 °C
8	Design Code	Maker STD.	Pressure Drop	0.2 bar
9	Area Class	Non-Hazardous	Outlet Dew Point	2~10 °C@PDP
10	Cooling Water Capacity	195 L/min	Design Pressure	9.7 barg
11	Cooling Water Pressure	2 ~ 3 barg	Design Temperature	70 °C
12	Cooling Water Temperature	32 °C	Ambient Temperature	32 °C
CONSTRUCTION				
14	Refrigerant	R-22	Dimension (W x L x H)	1,200 X 2,100 X 1,825 mm
15	Ref. Compressor Type	Scroll	Weight	1,200 kg
16	Ref. Compressor Capacity	15 HP	Power Consumption	13.4 kW
17	Condenser Type	Water Cooled	Inlet Connection	150A KS 10K SO.FF.
18	Condenser Capacity	20 HP	Outlet Connection	150A KS 10K SO.FF.
19	Heat Exchanger Type	Block	Cooling Water Connection	40A PT Union
20	Heat Exchanger Material	Aluminum	Drain Connection	15A PT Female Screw
21	Ref. Control Device	TEV	Color (Munsell)	5.7PB 4.1/9.9
22	Temp. Control Device	Hot Gas Bypass Valve		5.7PB 2.9/3.5
23	Drain Trap Type	Level Sensor		
STANDRAD FEATURES AND CONTROL				
25	Ref. Compressor	YES	Auto Drain	YES
26	Water Cooled Condenser	YES	Hot Gas Bypass Valve	YES
27	Cooling Water Regulating Valve	YES	Accumulator with Heat Exchanger	YES
28	Liquid Ref. Receiver	NO	Oil Separator	YES
29	Filter Dryer	YES	Ref. Pressure Switch	NO
30	Expansion Valve	YES	4.3" TFT LCD	YES
31	Heat Exchanger	YES	PCB Controller	YES
32	Ref. Pressure Transmitter	YES		
33	Air Pressure Gauge	YES		
34	Ref. Pressure Gauge	YES		
NOTES				
36				
37				
38				
39				
40				
41				
42				
43				
44				
45				
46				

10-MLH0090-CAH-VSD  
CON SWG

AIR INLET  
150A KS 10K SO.FF.

AIR OUTLET  
150A KS 10K SO.FF.

INSTALLATION SPACE

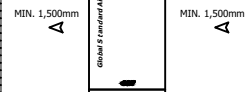

SPECIFICATION

INLET AIR TEMPERATURE	45°C
AMBIENT TEMPERATURE	32°C
INLET AIR PRESSURE	7 barg
CAPACITY	85 Nm <sup>3</sup> /min
AIR IN/OUT CONNECTION	150A KS 10K SO.FF.
C.W. IN/OUT CONNECTION	PT 40A
C.W. TEMP/ / PRESSURE	32°C / 2 ~ 3 barg
DIMENSION(WXDH, mm)	1,200 X 2,100 X 1,825
WEIGHT	1200 kg
POWER CONSUMPTION	13.4 kW
POWER SUPPLY	380/440V - 3PH - 50/60Hz

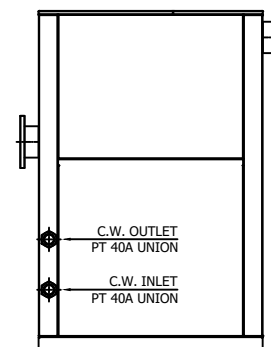
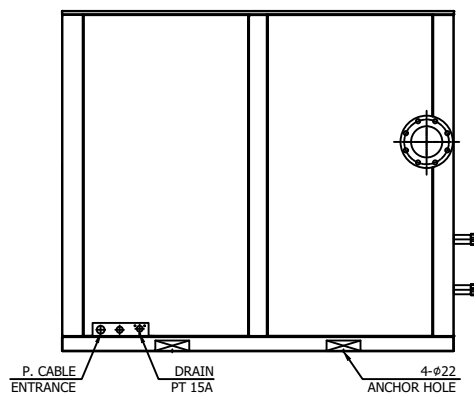
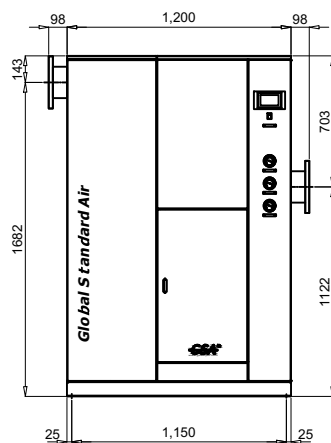
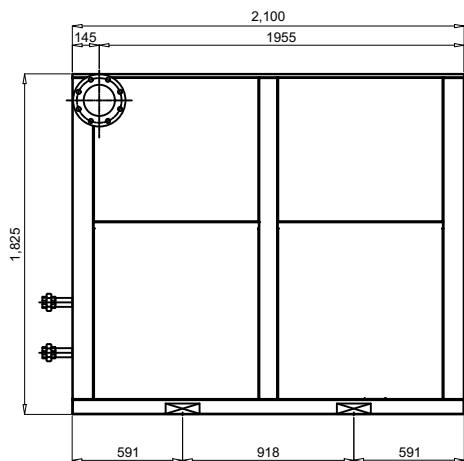

REV.	DATE	DESCRIPTION	DWG	CHK	APPD	APPD
2020.09.18		ISSUED FOR REFERENCE				

PROJECT

MANUFACTURER



TITLE

OUTLINE DRAWING

ITEM NO.	HYD-600HTW	DWG NO.	GSA-HYD-0600HTW-01	REV.	
SCALE	NONE				

(A4 : 297mm x 210mm)

ZD-MLH0090-GAH-VSD  
CON SWG

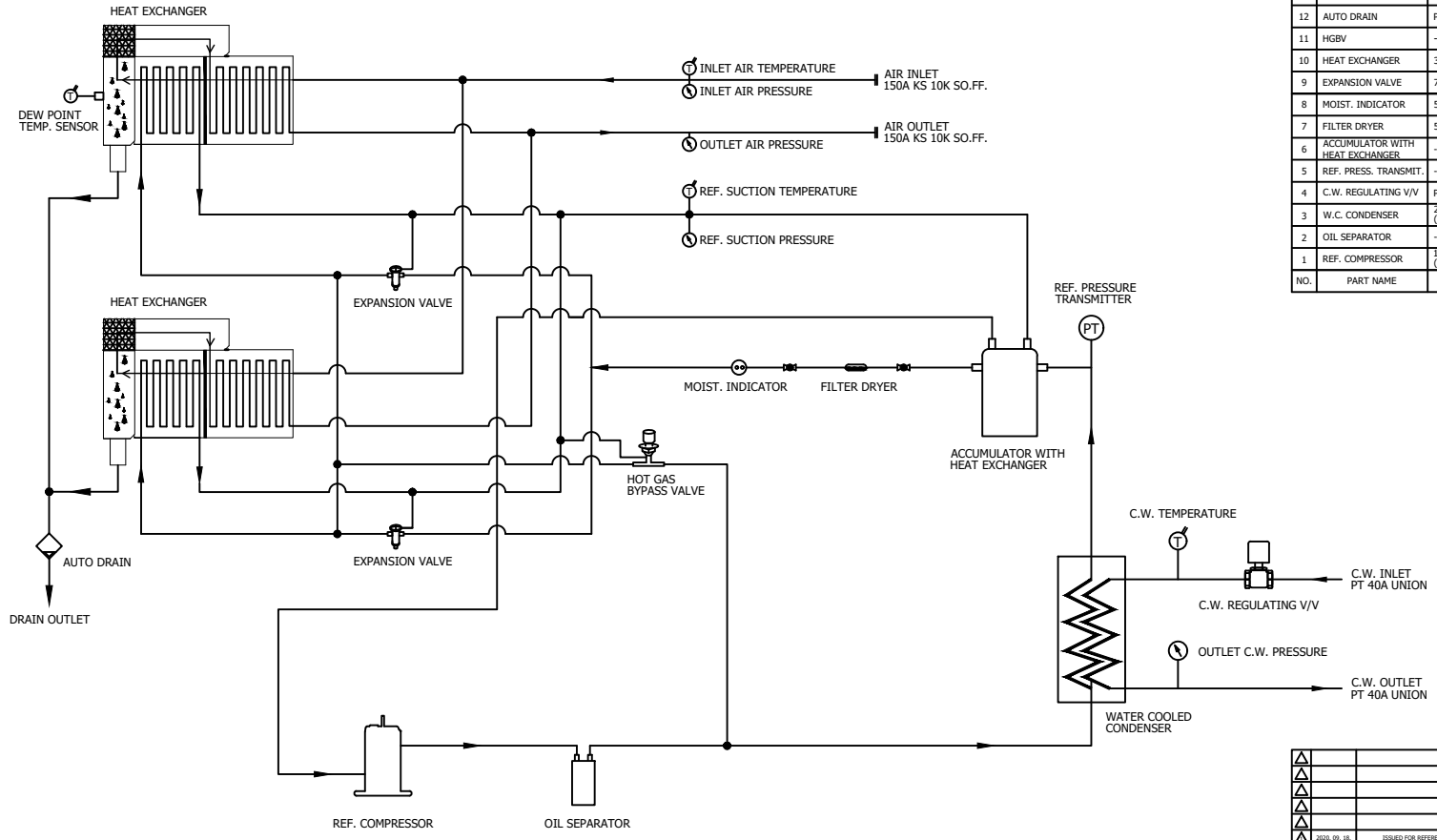

- ← AIR INLET LINE
- AIR OUTLET LINE
- ← REF. LOW PRESS. LINE
- REF. HIGH PRESS. LINE

DEW POINT	2~10°C @ PDP		
INLET AIR PRESSURE	7.0 barg		
INLET AIR TEMPERATURE	45°C		
CAPACITY	85 Nm <sup>3</sup> /min		
16	PRESS. GAUGE	COOLING WATER	1
15	PRESS. GAUGE	OUTLET AIR	1
14	PRESS. GAUGE	INLET AIR	1
13	PRESS. GAUGE	REF. SUCTION	1
12	AUTO DRAIN	PT 15A	1
11	HGBV	-	1
10	HEAT EXCHANGER	300 HP	2
9	EXPANSION VALVE	7.5 TON	2
8	MOIST. INDICATOR	5/8"	1
7	FILTER DRYER	5/8"	1
6	ACCUMULATOR WITH HEAT EXCHANGER	-	1
5	REF. PRESS. TRANSMIT.	-1 ~ 35 BAR	1
4	C.W. REGULATING V/V	PT 40A	1
3	W.C. CONDENSER	20 HP (CONDENSING CAPACITY)	1
2	OIL SEPARATOR	-	1
1	REF. COMPRESSOR	15 HP (COOLING CAPACITY)	1
NO.	PART NAME	DESCRIPTION	QTY

△										
△										
△										
△										
△										
△										
2020.09.18	ISSUED FOR REFERENCE									
REV.	DATE	DESCRIPTION	ENG	CHK	APPD	APPD	APPD	APPD	APPD	
PROJECT										
MANUFACTURER										
 <small>Global Standard Air &amp; Gas</small>										
TITLE										
PIPING & INSTRUMENTATION DRAWING										
ITEM NO.	HYD-600HTW	EDWG NO.	GSA-HYD-0600HTW-02							REV.
SCALE	NONE									

(A4 : 297mm x 210mm)

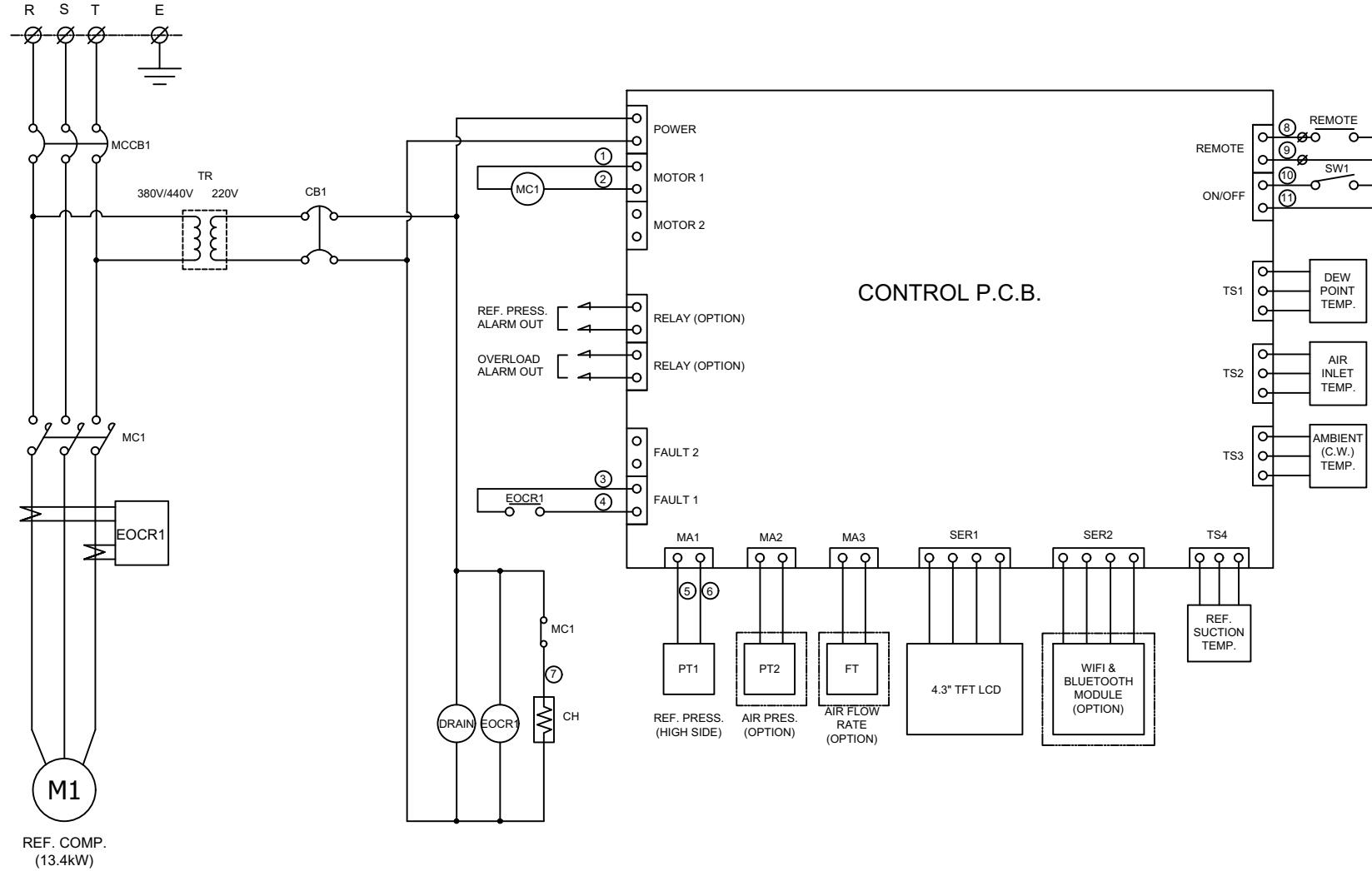

POWER SOURCE AC 380/440V, 3Ph, 50/60Hz		
11	PT1	REF. PRESSURE TRANSMITTER
10	TR	TRANSFORMER
9	SW1	SYSTEM ON/OFF SENSOR
8	CH	REF. COMP. HEATER
7	DRAIN	AUTO DRAIN VALVE
6	TS1 ~ TS4	TEMP. SENSOR
5	CB1	CIRCUIT BREAKER(CTRL)
4	MCCB1	CIRCUIT BREAKER(MAIN)
3	MC1	MAGNETIC CONTACTOR
2	EOCR1	OVERLOAD RELAY
1	M1	REF. COMPRESSOR
NO.	SYMBOL	DESCRIPTION

**\*REVERSE PHASE WARNING**  
 Be sure to check the rotation direction of the fan motor and the operating condition of the refrigerant compressor.  
 - The fan motor must rotate clockwise.  
 - When the refrigerant compressor is operating, the refrigerant suction pressure will be lowered.  
 When operating in reverse phase, the refrigerant compressor is damaged.  
 In case of reverse phase, change the position of 2 wires out of 3 wires of the power supply line.  
 Problems caused by incorrect power connection are not guaranteed.

△									
△									
△									
△									
△									
△	2020. 09. 18.	ISSUED FOR REFERENCE							
REV. NO.	DATE	DESCRIPTION	ENGR	CHK	APPR	APPR	APPR	APPR	APPR

PROJECT											
MANUFACTURER											
											
TITLE											
WIRING DRAWING											
ITEM NO.	HYD-600HTW	DWG NO.	GSA-HYD-0600HTW-03							REV.	△
SCALE	NONE										