	Refrigerated Air Dryer for High Temp.		Rev.	Date	Prepared By	Checked By	Approved By
			A	2020.09.23	WOO.I.H.	JO.S.J.	KIM.H.W.
	Water Cooled Type		B				
			C				
D							
Project Name			-		Model Name		HYD-300HTW
SPECIFICATION							
1							
2	Supply Voltage	380V	Inlet Flow Rate	47	Nm ³ /min		
3	Phase	3PH	Inlet Pressure	7	barg		
4	Frequency	60Hz	Inlet Temperature	45	°C		
5	Control use	220V	Outlet Flow Rate	50.3	Nm ³ /min		
6	Fulid	Compressed Air	Outlet Pressure	6.8	barg		
7	Location	Indoor	Outlet Temperature	33±5	°C		
8	Design Code	Maker STD.	Pressure Drop	0.2	bar		
9	Area Class	Non-Hazardous	Outlet Dew Point	2~10	°C@PDP		
10	Cooling Water Capacity	69 L/min	Design Pressure	14	barg		
11	Cooling Water Pressure	2 ~ 3 barg	Design Temperature	70	°C		
12	Cooling Water Temperature	32 °C	Ambient Temperature	32	°C		
CONSTRUCTION							
13							
14	Refrigerant	R-22	Dimension (W x L x H)	800 X 1,500 X 1,580	mm		
15	Ref. Compressor Type	Scroll	Weight	360	kg		
16	Ref. Compressor Capacity	7 HP	Power Consumption	5.5	kW		
17	Condenser Type	Water Cooled	Inlet Connection	100A	KS 10K SO.FF.		
18	Condenser Capacity	7.5 HP	Outlet Connection	100A	KS 10K SO.FF.		
19	Heat Exchanger Type	Block	Cooling Water Connection	32A	PT Union		
20	Heat Exchanger Material	Aluminum	Drain Connection	15A	PT Female Screw		
21	Ref. Control Device	TEV	Color (Munsell)	5.7PB 4.1/9.9			
22	Temp. Control Device	Hot Gas Bypass Valve		5.7PB 2.9/3.5			
23	Drain Trap Type	Level Sensor					
STANDRAD FEATURES AND CONTROL							
24							
25	Ref. Compressor	YES	Auto Drain	YES			
26	Water Cooled Condenser	YES	Hot Gas Bypass Valve	YES			
27	Cooling Water Regulating Valve	YES	Suction Line Accumulator	YES			
28	Liquid Ref. Receiver	YES	Oil Separator	NO			
29	Filter Dryer	YES	Ref. Pressure Switch	NO			
30	Expansion Valve	YES	4.3" TFT LCD	YES			
31	Heat Exchanger	YES	PCB Controller	YES			
32	Ref. Pressure Transmitter	YES					
33	Air Pressure Gauge	YES					
34	Ref. Pressure Gauge	YES					
NOTES							
35							
36							
37							
38							
39							
40							
41							
42							
43							
44							
45							
46							

10-MLH0000-CAH-VSD (ON DWG)

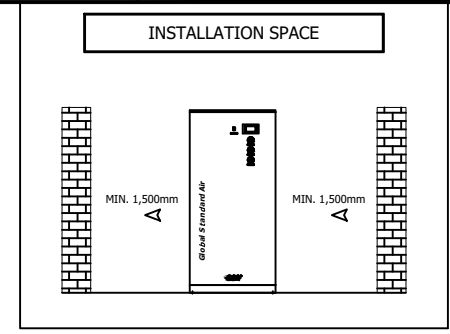

SPECIFICATION	
INLET AIR TEMPERATURE	45°C
AMBIENT TEMPERATURE	32°C
INLET AIR PRESSURE	7 barg
CAPACITY	47 Nm ³ /min
AIR IN/OUT CONNECTION	100A KS 10K SO.FF.
C.W. IN/OUT CONNECTION	PT 32A
C.W. TEMP. / PRESSURE	32°C / 2 ~ 3 barg
DIMENSION(WXDH, mm)	800 X 1,500 X 1,580
WEIGHT	360 kg
POWER CONSUMPTION	5.5 kW
POWER SUPPLY	380/440V - 3PH - 50/60HZ

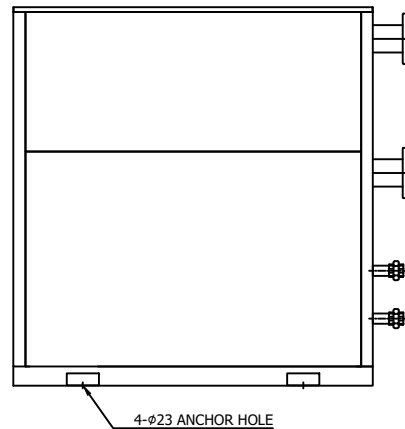
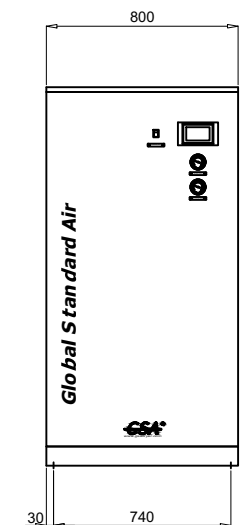
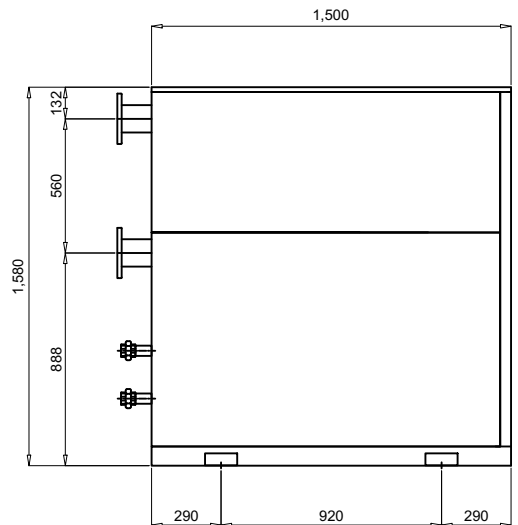
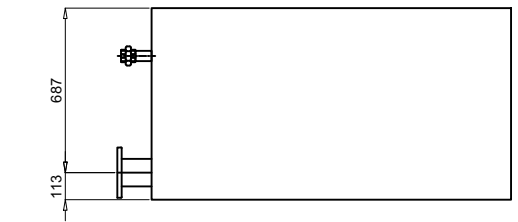
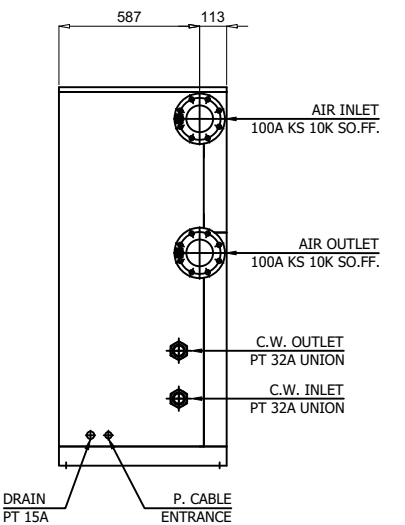

△										
△										
△										
△										
△										
△										
REV.	DATE	DESCRIPTION	ENG	CHK	APPD	APPD	APPD	APPD	APPD	
PROJECT	-									
MANUFACTURER										
TITLE	OUTLINE DRAWING									
ITEM NO.	HYD-300HTW	EDWG NO.	GSA-HYD-0300HTW-01							REV.
SCALE	NONE								△	

(A4 : 297mm x 210mm)

ZD-MLH00E0-QAH-VSD
ON DWG

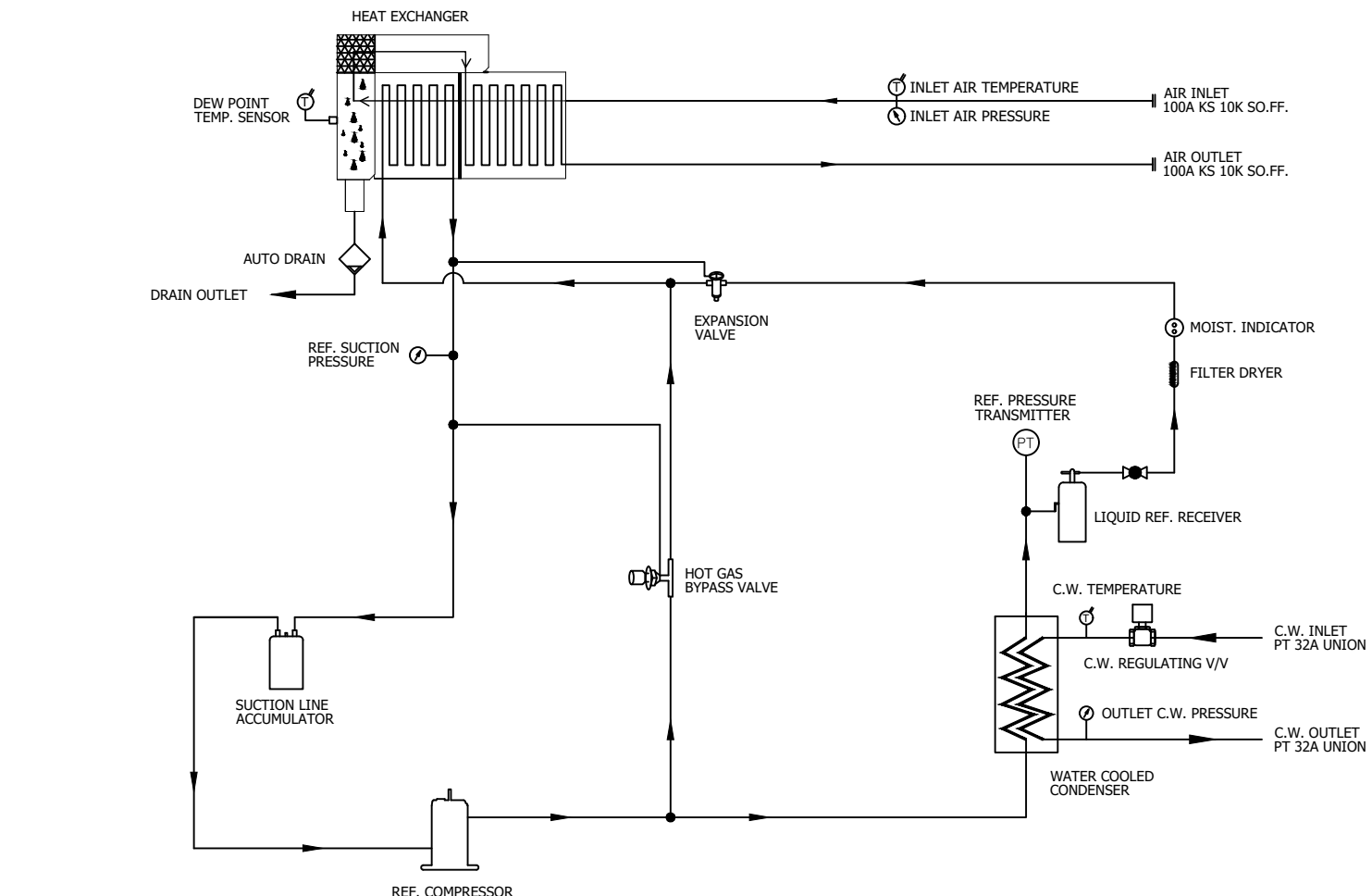

- ← AIR INLET LINE
- AIR OUTLET LINE
- ← REF. LOW PRESS. LINE
- REF. HIGH PRESS. LINE

DEW POINT	2~10°C @ PDP		
INLET AIR PRESSURE	7.0 BARG		
INLET AIR TEMPERATURE	45°C		
CAPACITY	47 Nm ³ /min		
15 PRESS. GAUGE	OUTLET COOLING WATER	1	
14 PRESS. GAUGE	INLET AIR	1	
13 PRESS. GAUGE	REF. SUCTION	1	
12 ACCUMULATOR	-	1	
11 AUTO DRAIN	PT 15A	1	
10 HEAT EXCHANGER	300 HP	1	
9 HGBV	-	1	
8 EXPANSION VALVE	7.5 TON	1	
7 MOIST. INDICATOR	1/2"	1	
6 FILTER DRYER	1/2"	1	
5 REF. RECEIVER	-	1	
4 REF. PRESS. TRANSMIT.	-1 ~ 35 BAR	1	
3 C.W. REGUL. V/V	PT 32A	1	
2 W.C. CONDENSER	7.5 HP (CONDENSING CAPACITY)	1	
1 REF. COMPRESSOR	7 HP (COOLING CAPACITY)	1	
NO.	PART NAME	DESCRIPTION	QTY

△										
△										
△										
△										
△	2020. 09. 28	ISSUED FOR REFERENCE								
REV.	DATE	DESCRIPTION	ENG	CHK	APPD	APPD	APPD	APPD		
PROJECT										
MANUFACTURER										
 <small>Global Standard Air & Gas</small>										
TITLE										
PIPING & INSTRUMENTATION DRAWING										
ITEM NO.	HYD-300HTW	DWG NO.	GSA-HYD-0300HTW-02							REV.
SCALE	NONE									△
(A4 : 297mm x 210mm)										

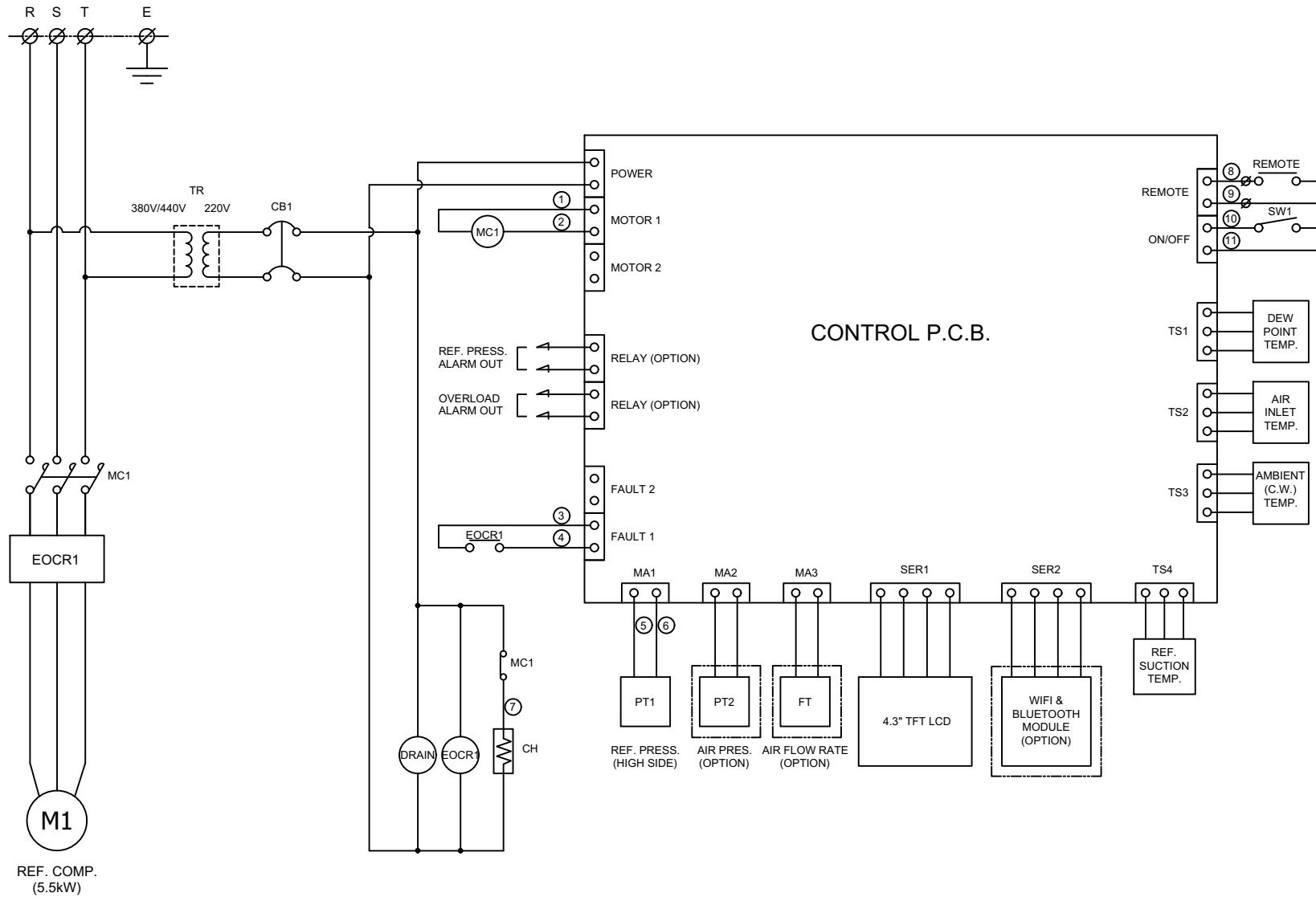

POWER SOURCE		
AC 380/440V, 3Ph, 50/60Hz		
10	PT1	REF. PRESSURE TRANSMITTER
9	TR	TRANSFORMER
8	SW1	SYSTEM ON/OFF SWITCH
7	CH	REF. COMP. HEATER
6	DRAIN	AUTO DRAIN VALVE
5	TS1 ~ TS4	TEMP. SENSOR
4	CB1	CIRCUIT BREAKER(CTRL)
3	MC1	MAGNETIC CONTACTOR
2	EOCR1	OVERLOAD RELAY
1	M1	REF. COMPRESSOR
NO.	SYMBOL	DESCRIPTION

***REVERSE PHASE WARNING**
 Be sure to check the rotation direction of the fan motor and the operating condition of the refrigerant compressor.
 - The fan motor must rotate clockwise.
 - When the refrigerant compressor is operating, the refrigerant suction pressure will be lowered.
 When operating in reverse phase, the refrigerant compressor is damaged.
 In case of reverse phase, change the position of 2 wires out of 3 wires of the power supply line.
 Problems caused by incorrect power connection are not guaranteed.

REV. NO.	DATE	DESCRIPTION	ENG	CHK	APPD	APPD	APPD
2020.09.28		ISSUED FOR REFERENCE					

MANUFACTURER
GSA
Global Service Automation

TITLE
WIRING DRAWING

ITEM NO.	HYD-300HTW	DWG NO.	GSA-HYD-0300HTW-03	REV.
SCALE	NONE			