

	<b>Refrigerated Air Dryer</b>		Rev.	Date	Prepared By	Checked By	Approved By
			A	2020.09.23	WOO.I.H.	JO.S.J.	KIM.H.W.
	<b>Water Cooled Type</b>		B				
			C				
D							
Project Name			-		Model Name		HYD-250WN
<b>SPECIFICATION</b>							
1							
2	Supply Voltage	380V	Inlet Flow Rate	41.7	Nm3/min		
3	Phase	3PH	Inlet Pressure	7	barg		
4	Frequency	60Hz	Inlet Temperature	38	°C		
5	Control use	220V	Outlet Flow Rate	41.7	Nm3/min		
6	Fulid	Compressed Air	Outlet Pressure	6.8	barg		
7	Location	Indoor	Outlet Temperature	28±5	°C		
8	Design Code	Maker STD.	Pressure Drop	0.2	bar		
9	Area Class	Non-Hazardous	Outlet Dew Point	2~10	°C@PDP		
10	Cooling Water Capacity	67.5 L/min	Design Pressure	14	barg		
11	Cooling Water Pressure	2 ~ 3 barg	Design Temperature	70	°C		
12	Cooling Water Temperature	32 °C	Ambient Temperature	32	°C		
<b>CONSTRUCTION</b>							
13							
14	Refrigerant	R-22	Dimension (W x L x H)	700 X 1,200 X 1,580	mm		
15	Ref. Compressor Type	Scroll	Weight	250	kg		
16	Ref. Compressor Capacity	5 HP	Power Consumption	4	kW		
17	Condenser Type	Water Cooled	Inlet Connection	100A	KS 10K SO.FF.		
18	Condenser Capacity	5 HP	Outlet Connection	100A	KS 10K SO.FF.		
19	Heat Exchanger Type	Block	Cooling Water Connection	32A	PT Union		
20	Heat Exchanger Material	Aluminum	Drain Connection	15A	PT Female Screw		
21	Ref. Control Device	TEV	Color (Munsell)	5.7PB 4.1/9.9			
22	Temp. Control Device	Hot Gas Bypass Valve		5.7PB 2.9/3.5			
23	Drain Trap Type	Level Sensor					
<b>STANDRAD FEATURES AND CONTROL</b>							
24							
25	Ref. Compressor	YES	Auto Drain	YES			
26	Water Cooled Condenser	YES	Hot Gas Bypass Valve	YES			
27	Cooling Water Regulating Valve	YES	Suction Line Accumulator	YES			
28	Liquid Ref. Receiver	YES	Oil Separator	NO			
29	Filter Dryer	YES	Ref. Pressure Switch	NO			
30	Expansion Valve	YES	4.3" TFT LCD	YES			
31	Heat Exchanger	YES	PCB Controller	YES			
32	Ref. Pressure Transmitter	YES					
33	Air Pressure Gauge	YES					
34	Ref. Pressure Gauge	YES					
<b>NOTES</b>							
35							
36							
37							
38							
39							
40							
41							
42							
43							
44							
45							
46							

10-NM05Z0-QAH-VSD  
CON DWG

SPECIFICATION	
INLET AIR TEMPERATURE	38°C
AMBIENT TEMPERATURE	32°C
C.W. TEMP. / PRESS.	32°C / 2~3 barg
INLET AIR PRESSURE	7 barg
CAPACITY	41.7 Nm <sup>3</sup> /min
AIR IN/OUT CONNECTION	100A KS 10K SO.FF.
C.W IN/OUT CONNECTION	PT 32A
DIMENSION(WXDXH, mm)	700 X 1,200 X 1,580
WEIGHT	250 kg
POWER CONSUMPTION	4 kW
POWER SUPPLY	380/440V - 3PH - 50/60HZ

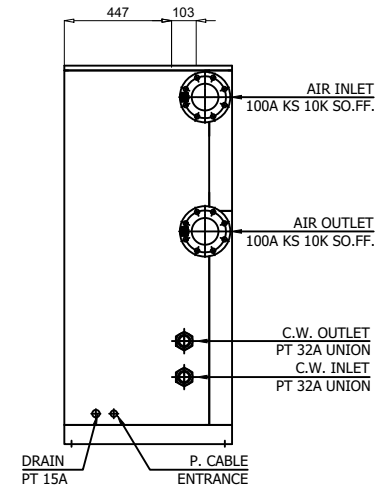
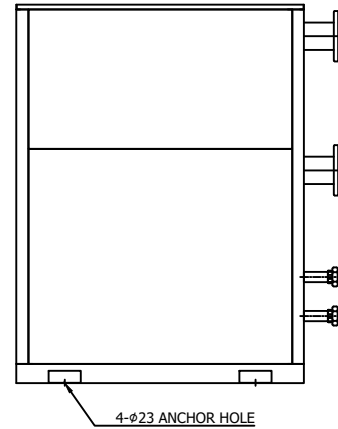
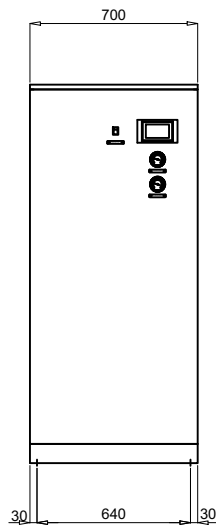
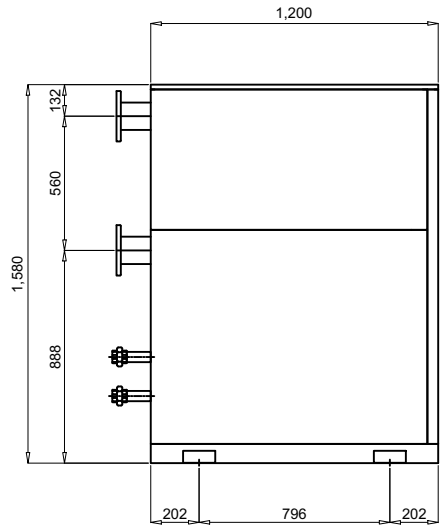

REV.	DATE	DESCRIPTION	ENG.	CHK.	APPD.	APPD.
2020.09.23		ISSUED FOR REFERENCE				
PROJECT						
MANUFACTURER						
 GSA Global Standard Air & Gas						
TITLE						
OUTLINE DRAWING						
ITEM NO.	HYD-250WN	DWG NO.		GSA-HYD-0250WN-01		
SCALE	NONE					

(A4 : 297mm x 210mm)

Z0-NM05Z0-QAH-YSD  
ON DWG

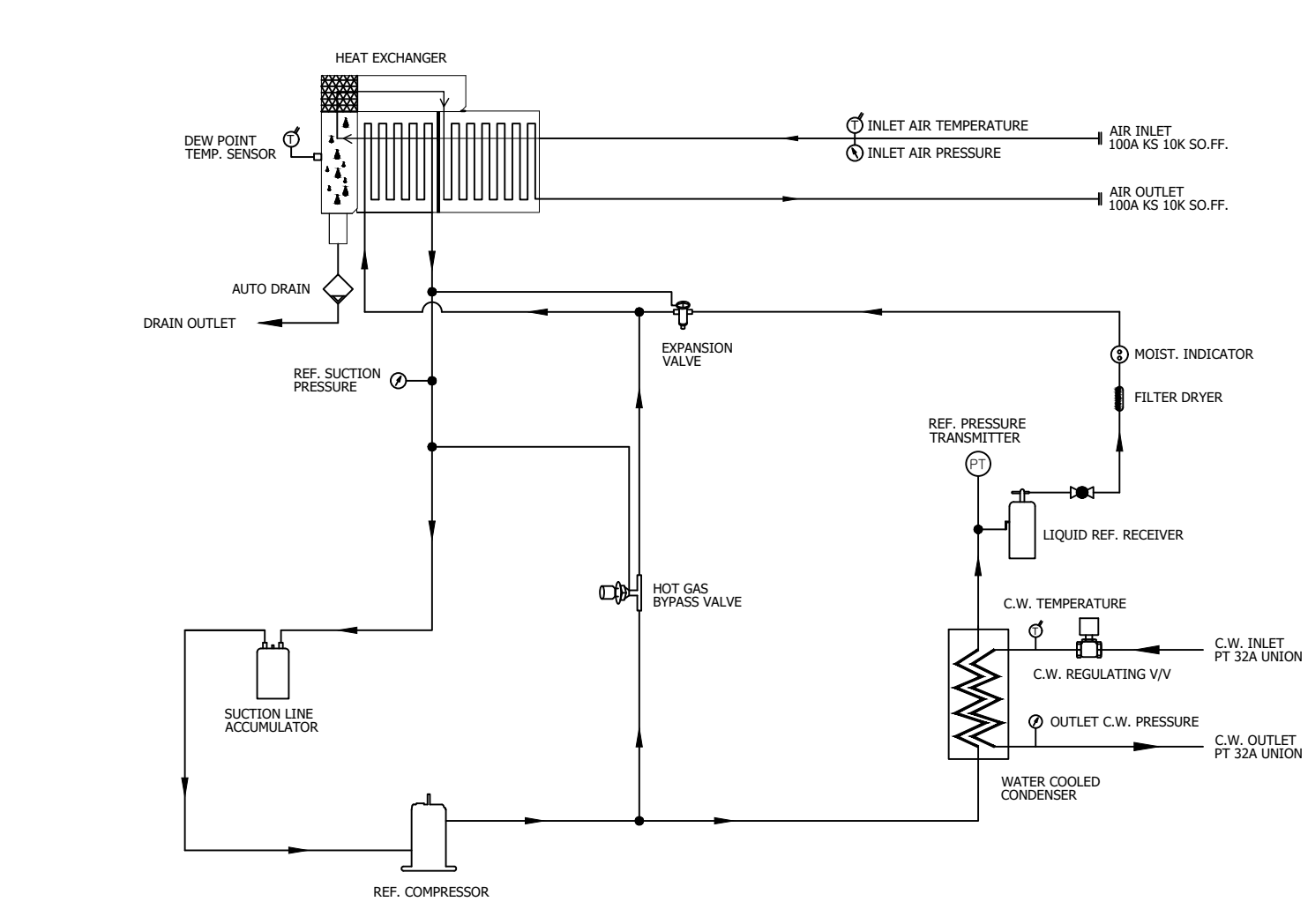

- AIR INLET LINE
- AIR OUTLET LINE
- REF. LOW PRESS. LINE
- REF. HIGH PRESS. LINE

DEW POINT	2~10°C @ PDP		
INLET AIR PRESSURE	7.0 barg		
INLET AIR TEMPERATURE	38°C		
CAPACITY	41.7 Nm <sup>3</sup> /min		
15	PRESS. GAUGE	OUTLET COOLING WATER	1
14	PRESS. GAUGE	INLET AIR	1
13	PRESS. GAUGE	REF. SUCTION	1
12	ACCUMULATOR	-	1
11	AUTO DRAIN	PT 15A	1
10	HEAT EXCHANGER	300 HP	1
9	HGBV	-	1
8	EXPANSION VALVE	5 TON	1
7	MOIST. INDICATOR	1/2"	1
6	FILTER DRYER	1/2"	1
5	REF. RECEIVER	-	1
4	REF. PRESS. TRANSMIT.	-1 ~ 35 BAR	1
3	C.W. REGUL. V/V	PT 32A	1
2	W.C. CONDENSER	5 HP (CONDENSING CAPACITY)	1
1	REF. COMPRESSOR	5 HP (COOLING CAPACITY)	1
NO.	PART NAME	DESCRIPTION	QTY

△									
△									
△									
△									
△	2020. 09. 23	ISSUED FOR REFERENCE							
REV.	DATE	DESCRIPTION	ENG	CHK	APPD	APPD			
PROJECT									
MANUFACTURER									
<b>GSA</b> Global Standard Air & Gas									
TITLE									
PIPING & INSTRUMENTATION DRAWING									
ITEM NO.	HYD-250WN	EDWG NO.	GSA-HYD-0250WN-02						
SCALE	NONE								
(A4 : 297mm x 210mm)									

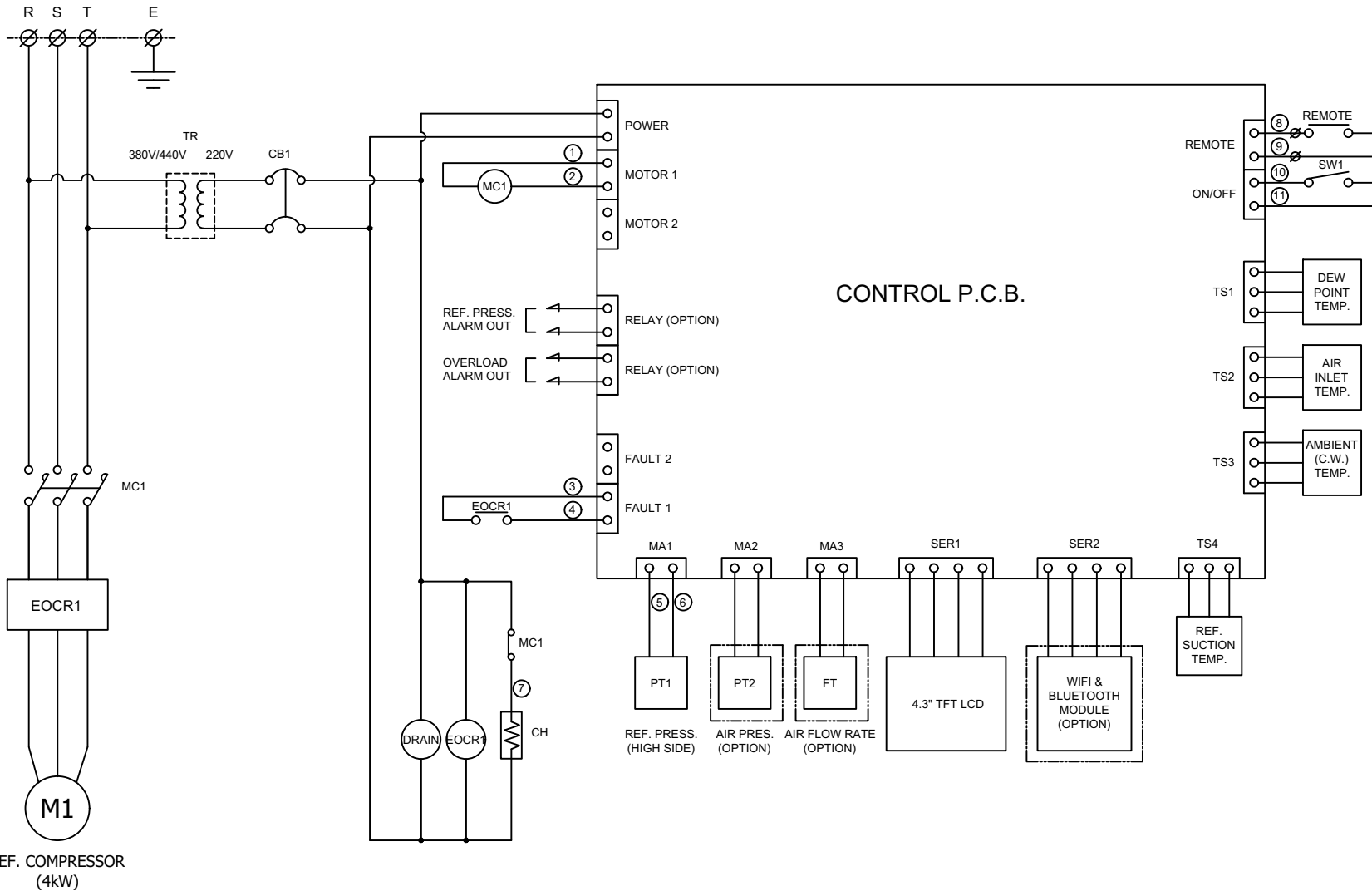

POWER SOURCE		
AC 380/440V, 3Ph, 50/60Hz		
10	PT1	REF. PRESSURE TRANSMITTER
9	TR	TRANSFORMER
8	SW1	SYSTEM ON/OFF SWITCH
7	C.H.	REF. COMP. HEATER
6	DRAIN	AUTO DRAIN VALVE
5	TS1 ~ TS4	TEMP. SENSOR
4	CB1	CIRCUIT BREAKER(CTRL)
3	MC1	MAGNETIC CONTACTOR
2	EOCR1	OVERLOAD RELAY
1	M1	REF. COMPRESSOR
NO.	SYMBOL	DESCRIPTION

**\*REVERSE PHASE WARNING**

Be sure to check the operating condition of the refrigerant compressor.

- When the refrigerant compressor is operating, the refrigerant suction pressure will be lowered.

When operating in reverse phase, the refrigerant compressor is damaged.

In case of reverse phase, change the position of 2 wires out of 3 wires of the power supply line.

Problems caused by incorrect power connection are not guaranteed.

REV. NO.	DATE	DESCRIPTION	ENG	CHK	APPD	APPD	APPD
2020.09.23.		ISSUED FOR REFERENCE					

PROJECT: \_\_\_\_\_

MANUFACTURER: **GSA**  
Global Service Air & Gas

TITLE: **WIRING DRAWING**

ITEM NO.	HYD-250WN	DWG NO.	GSA-HYD-0250WN-03	REV.	△
SCALE	NONE				