	<b>Refrigerated Air Chiller</b>	Rev.	Date	Prepared By	Checked By	Approved By
		A	2020.09.22	WOO.I.H.	JO.S.J.	KIM.H.W.
	<b>Air Cooled Type</b>	B				
		C				
D						
Project Name		-		Model Name		HYD-200CH
<b>SPECIFICATION</b>						
1						
2	Supply Voltage	380V	Inlet Flow Rate	30	Nm3/min	
3	Phase	3PH	Inlet Pressure	7	barg	
4	Frequency	60Hz	Inlet Temp.	32	°C	
5	Control use	220V	Inlet Air Condition	Dried Air		
6	Fluid	Compressed Air	Outlet Flow Rate	30	Nm3/min	
7	Location	Indoor	Outlet Pressure	6.8	barg	
8	Design Code	Maker STD.	Outlet Temp.	10	°C	
9	Area Class	Non-Hazardous	Pressure Drop	0.2	bar	
10			Design Pressure	14	barg	
11			Design Temperature	70	°C	
12			Ambient Temperature	32	°C	
<b>CONSTRUCTION</b>						
13						
14	Refrigerant	R-22	Dimension (W x L x H)	550 X 1,200 X 1,447	mm	
15	Ref. Compressor Type	Scroll	Weight	225	kg	
16	Ref. Compressor Capacity	5 HP	Power Consumption	4.18	kW	
17	Condenser Type	Air Cooled	Inlet Connection	80A	KS 10K SO.FF.	
18	Condenser Fan Motor	0.4 kW	Outlet Connection	80A	KS 10K SO.FF.	
19		1 EA	Drain Connection(Optional)	15A	PT Female Screw	
20	Condenser Fan Size	600 mm	Color (Munsell)	5.7PB 4.1/9.9		
21	Condenser Capacity	4 HP		5.7PB 2.9/3.5		
22	Condenser Material	Aluminum & Copper				
23	Heat Exchanger Type	Block				
24	Heat Exchanger Material	Aluminum				
25	Ref. Control Device	TEV				
26						
27						
<b>STANDRAD FEATURES AND CONTROL</b>						
28						
29	Ref. Compressor	YES	Ref. Pressure Gauge	YES		
30	Air Cooled Condenser	YES	Air Pressure Gauge	YES		
31	Fan Motor	YES	Hot Gas Bypass Valve	NO		
32	Ref. Pressure Transmitter	YES	Suction Line Accumulator	YES		
33	Liquid Ref. Receiver	YES	Oil Separator	NO		
34	Filter Dryer	YES	4.3" TFT LCD	YES		
35	Moisture Indicator	YES	PCB Controller	YES		
36	Expansion Valve	YES				
37	Heat Exchanger	YES				
38	Temperature Sensor	YES				
<b>NOTES</b>						
39						
40						
41						
42						
43						
44						
45						
46						

AIR INLET  
80A KS 10K SO.FF.

AIR INLET  
80A KS 10K SO.FF.

COOLING AIR DIRECTION

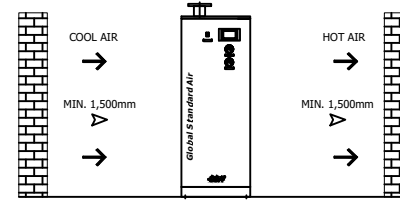

SPECIFICATION	
INLET/OUTLET AIR TEMP.	32°C / 10°C
INLET AIR PRESSURE	7 barg
INLET AIR CONDITION	DRIED AIR
CAPACITY	30.0 Nm <sup>3</sup> /min
IN/OUT CONNECTION	80A KS 10K SO.FF.
DIMENSION(WXDXH, mm)	550 X 1,200 X 1,447
WEIGHT	225 kg
POWER CONSUMPTION	4.18 kW
POWER SUPPLY	380/440V - 3PH - 50/60Hz

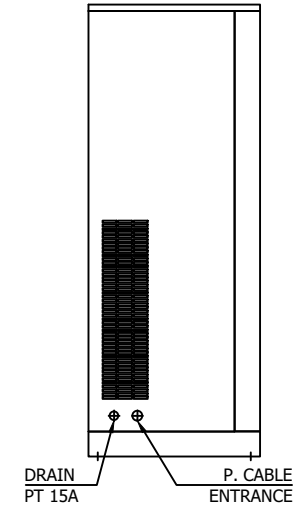
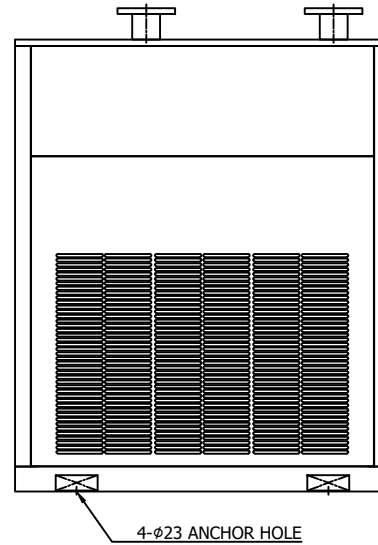
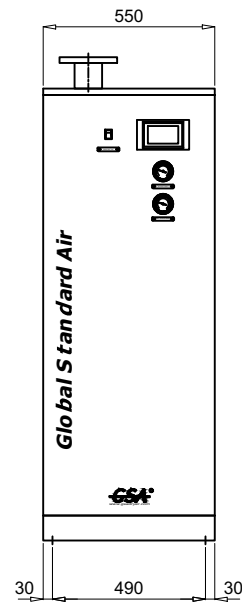
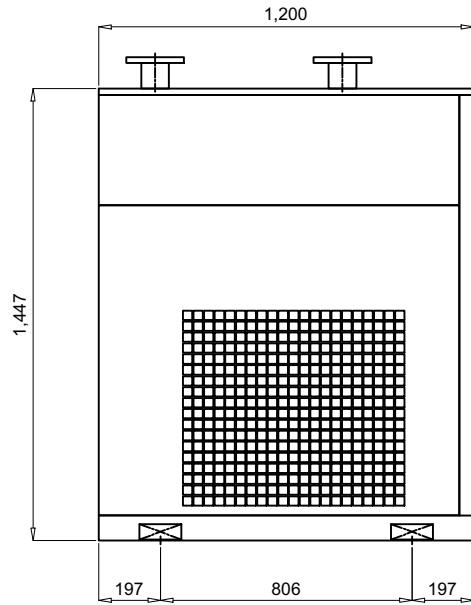

△											
△											
△											
△											
△											
REV. NO.	DATE	DESCRIPTION	DWG	CHK	APPD	APPD	APPD	APPD	APPD		
2020.09.21		ISSUED FOR REFERENCE									
PROJECT											
MANUFACTURER											
 Global Standard Air & Gas											
TITLE											
OUTLINE DRAWING											
ITEM NO.	HYD-200CH	DWG NO.	GSA-HYD-0200CH-01							REV.	△
SCALE	NONE										

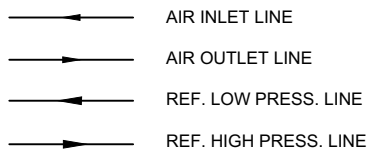
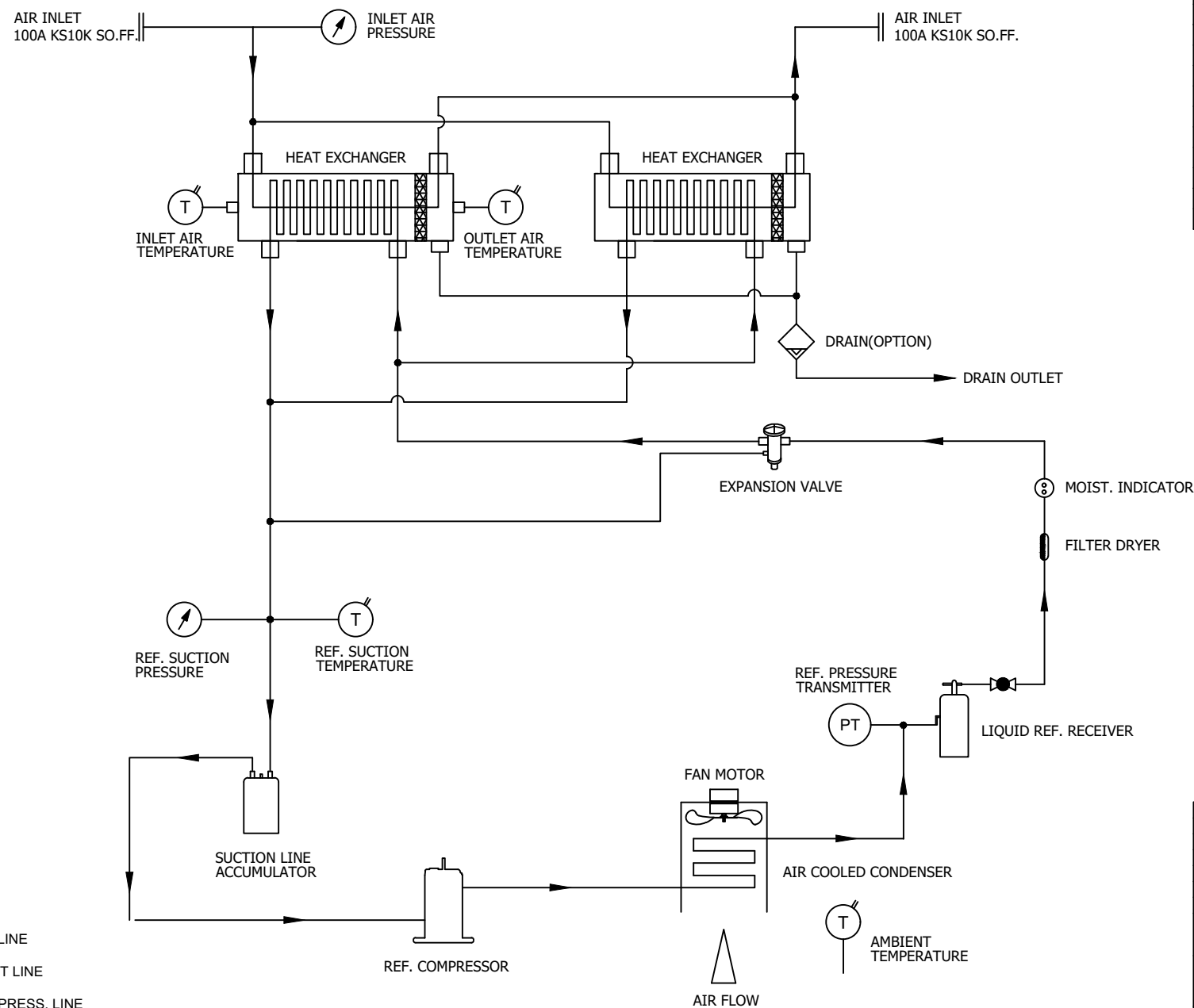

INLET / OUTLET AIR TEMP.	32°C / 10°C		
INLET AIR PRESSURE	7 barg		
INLET AIR CONDITION	DRIED AIR		
CAPACITY	30.0 Nm <sup>3</sup> /min		
12 DRAIN	OPTION	1	
11 SUCTION LINE ACCUMULA.	-	1	
10 REF. PRESS. GAUGE	LOW SIDE	1	
9 HEAT EXCHANGER	100 HP	2	
8 EXPANSION VALVE	5 TON	1	
7 MOIST. INDICATOR	1/2"	1	
6 FILTER DRYER	1/2"	1	
5 REF. PRESSURE TRANSMIT.	-1 ~ 35 BARG	1	
4 LIQUID REF. RECEIVER	-	1	
3 FAN MOTOR	0.4KW 6P ø600	1	
2 A/C CONDENSER	4 HP	1	
1 REF. COMPRESSOR	5 HP	1	
NO.	PART NAME	DESCRIPTION	QTY

△											
△											
△											
△											
△											
REV. NO.	DATE	DESCRIPTION	DWG	CHK	APPD	APPD	APPD	APPD	APPD	APPD	
PROJECT	-										
MANUFACTURER											
TITLE	PIPING & INSTRUMENTATION DRAWING										
ITEM NO.	HYD-200CH	DWG NO.	GSA-HYD-0200CH-02							REV.	△
SCALE	NONE										

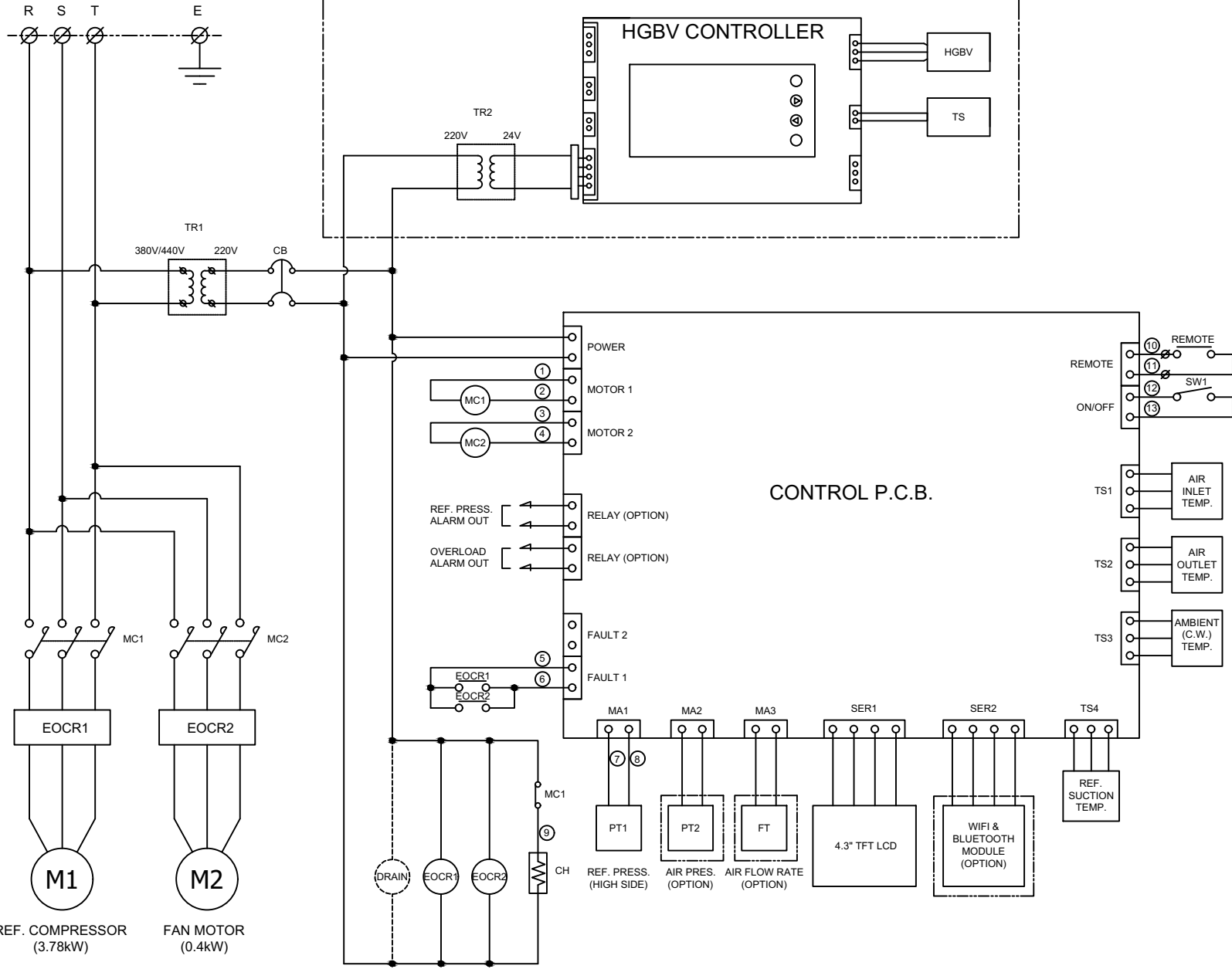

POWER SOURCE  
AC 220/380/440V, 3Ph, 50/60Hz

11	DRAIN	OPTION
10	CH	REF. COMP. HEATER
9	PT1	REF. PRESSURE TRANSMITTER
8	TS1 ~ TS4	TEMP. SENSOR INPUT
7	SW1	START/STOP SWITCH
6	CB	CIRCUIT BREAKER(CONTROL)
5	TR1	TRANSFORMER
4	EOCR1, EOCR2	REF. COMPRESSOR OVERLOAD RELAY
3	MC1, MC2	MAGNETIC CONTACTOR
2	M2	FAN MOTOR
1	M1	REF. COMPRESSOR
NO.	SYMBOL	DESCRIPTION

**\*REVERSE PHASE WARNING**  
Be sure to check the rotation direction of the fan motor and the operating condition of the refrigerant compressor.

- The fan motor must rotate clockwise.
- When the refrigerant compressor is operating, the refrigerant suction pressure will be lowered.

When operating in reverse phase, the refrigerant compressor is damaged.

In case of reverse phase, change the position of 2 wires out of 3 wires of the power supply line.

Problems caused by incorrect power connection are not guaranteed.

△													
△													
△													
△													
REV. NO.	2020. 09. 21	ISSUED FOR REFERENCE											
DATE		DESCRIPTION	DWG	CHK	APPD	APPD	APPD						
PROJECT													
MANUFACTURER													
 Global Service Air & Cool													
TITLE													
WIRING DRAWING													
ITEM NO.	HYD-200CH	DWG NO.	GSA-HYD-0200CH-03										REV.
SCALE	NONE												