	<b>Refrigerated Air Dryer</b>		Rev.	Date	Prepared By	Checked By	Approved By
			1	2019.01.15	LEE.S.M.	JO.S.J.	KIM.H.W.
	<b>Air Cooled Type</b>		2				
			3				
			4				
Project Name		-		Model Name		HYD-150N	
<b>SPECIFICATION</b>							
1							
2	Supply Voltage	480V	Inlet Flow Rate	21	Nm3/min		
3	Phase	3PH	Inlet Pressure	9	barg		
4	Frequency	60Hz	Inlet Temp.	38	°C		
5	Control use	220V	Outlet Flow Rate	21	Nm3/min		
6	Fulid	Compressed Air	Outlet Pressure	8.8	barg		
7	Location	Indoor	Outlet Temp.	28±5	°C		
8	Design Code	Maker STD.	Pressure Drop	0.2	bar		
9	Area Class	Non-Hazardous	Outlet Dew Point	2~10	°C		
10			Design Pressure	9.7	barg		
11			Design Temperature	70	°C		
12			Ambient Temperature	32	°C		
<b>CONSTRUCTION</b>							
13							
14	Refrigerant	R-22	Dimension (W x L x H)	565 X 1,005 X 1,330	mm		
15	Ref. Compressor Type	Scroll	Weight	172	kg		
16	Ref. Compressor Capacity	3 HP	Power Consumption	2.86	kW		
17	Condenser Type	Air Cooled	Inlet Connection	65A	PT Female Screw		
18	Condenser Fan Motor	0.4 kW	Outlet Connection	65A	PT Female Screw		
19		1 EA	Drain Connection	15A	PT Female Screw		
20	Condenser Fan Size	550 mm	Color (Munsell)	5.7PB 4.1/9.9			
21	Condenser Capacity	3 HP		5.7PB 2.9/3.5			
22	Condenser Material	Aluminum & Copper					
23	Heat Exchanger Type	Block					
24	Heat Exchanger Material	Aluminum					
25	Ref. Control Device	TEV					
26	Temp. Control Device	Hot Gas Bypass Valve					
27	Drain Trap Type	Electric					
<b>STANDRAD FEATURES AND CONTROL</b>							
28							
29	Fan Controller	YES	Ref. Compressor	YES			
30	Ref. Liquid Filter Dryer	YES	Expansion Valve	YES			
31	Overload Relay	YES	Hot Gas Bypass Valve	YES			
32	PCB Controller	YES	Air Cooled Condenser	YES			
33	Fan Motor Test Button	YES	Accumulator	YES			
34	Air Pressure Gauge	NO	Liquid Ref. Receiver	YES			
35	Ref. Pressure Gauge	YES	Oil Separator	NO			
36	Dual Pressure Switch	YES	Circuit Breaker	NO			
37	Moisture Indicator	YES	Ref. Compressor Heater	YES			
38	Drain	YES					
<b>NOTES</b>							
39							
40							
41							
42							
43							
44							
45							
46							

T0-N0510-QAH-VSS  
CON DWG

COOLING AIR DIRECTION

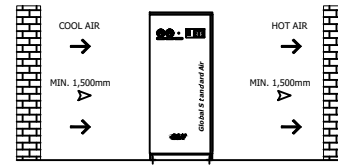

SPECIFICATION

INLET AIR TEMPERATURE	38°C
AMBIENT TEMPERATURE	32°C
INLET AIR PRESSURE	7 barg
CAPACITY	21.0 Nm <sup>3</sup> /min
IN/OUT CONNECTION	PT 65A
DIMENSION(WXDXH,mm)	565 X 1,005 X 1,330
WEIGHT	172 kg
POWER CONSUMPTION	2.86 kW
POWER SUPPLY	380/440V - 3PH - 50/60Hz

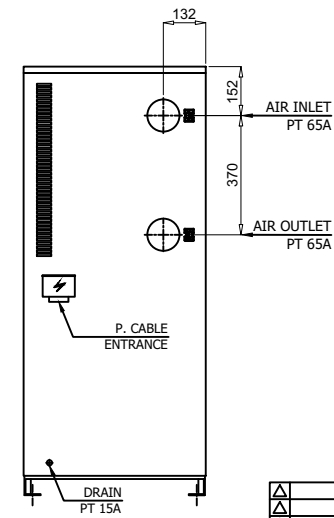
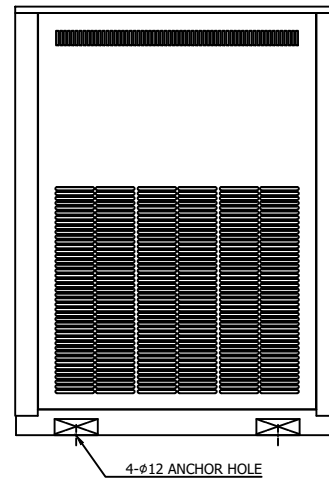
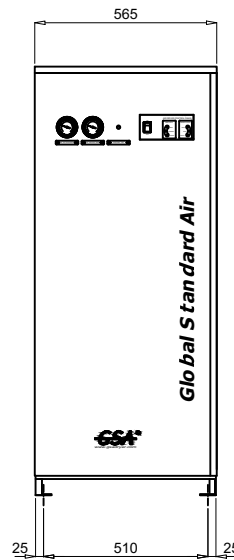
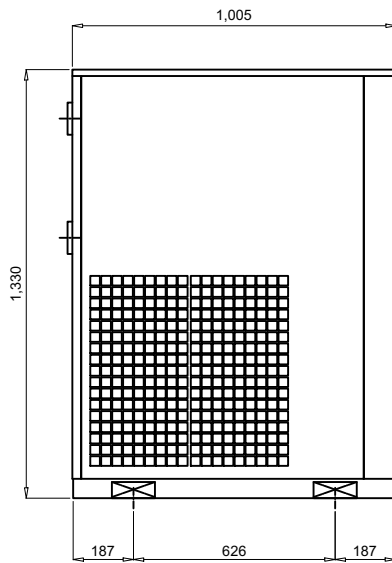
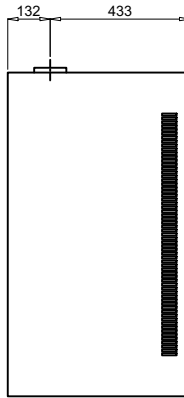

REV	DATE	DESCRIPTION	DWG	CHK	APPD	APPD
2020. 03. 20.		CHANGE OF CONTROL PCB				
2018. 11. 26.		ISSUED FOR REFERENCE				

PROJECT  
-

MANUFACTURER  
**GSA**  
Global Standard Air & Gas

TITLE  
OUTLINE DRAWING

ITEM NO.	HYD-150N	DWG NO.	GSA-HYD-0150N-01	REV	
SCALE	NONE				

Z0-N0510-QAH-VSS  
CON SWG

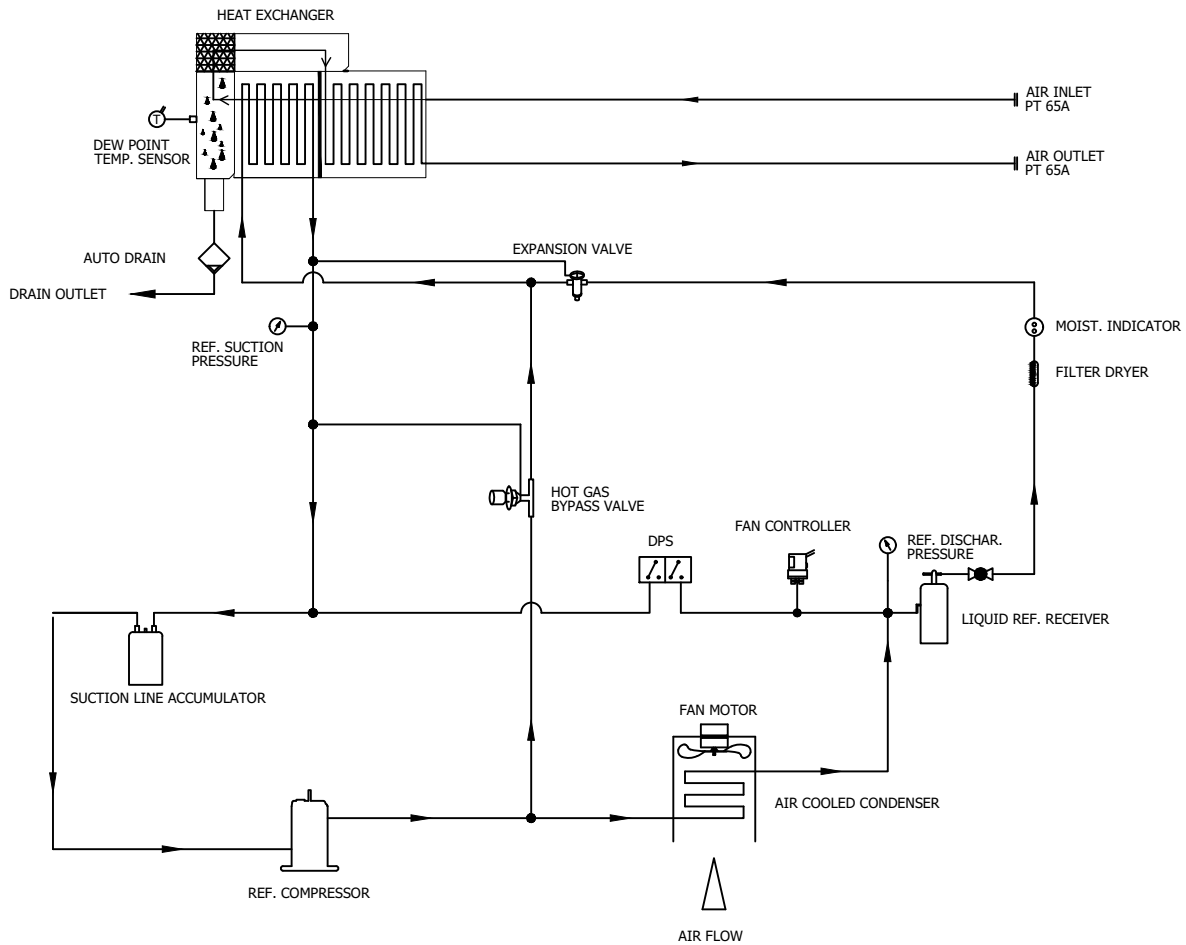

- ← AIR INLET LINE
- AIR OUTLET LINE
- ← REF. LOW PRESS. LINE
- REF. HIGH PRESS. LINE

DEW POINT	2~10°C @ PDP		
INLET AIR PRESSURE	7.0 BARG		
INLET AIR TEMPERATURE	38°C		
CAPACITY	21.0 Nm <sup>3</sup> /min		
15	PRESS. GAUGE	REF. DISCHARGE	1
14	PRESS. GAUGE	REF. SUCTION	1
13	ACCUMULATOR	-	1
12	AUTO DRAIN	PT 15A	1
11	HEAT EXCHANGER	150 HP	1
10	HGBV	-	1
9	EXPANSION VALVE	3 TON	1
8	MOIST. INDICATOR	3/8"	1
7	FILTER DRYER	3/8"	1
6	REF. RECEIVER	-	1
5	DPS	REF. LOW / HIGH PRESS. SW.	1
4	FAN CONTROLLER	I2 ~ 18 BARG	1
3	FAN MOTOR	0.4KW 6P #550	1
2	A/C CONDENSER	3 HP (CONDENSING CAPACITY)	1
1	REF. COMPRESSOR	3 HP (COOLING CAPACITY)	1
NO.	PART NAME	DESCRIPTION	QTY

△									
△									
△									
△	2020. 09. 16.	PARTS NUMBER DELETE							
△	2018. 11. 26.	ISSUED FOR REFERENCE							
REV.	DATE	DESCRIPTION	ENG	CHK	APPD	APPD			
PROJECT									

PROJECT

MANUFACTURER  
**GSA**  
Global Standard Air & Gas

TITLE  
**PIPING & INSTRUMENTATION DRAWING**

ITEM NO.	HYD-150N	DWG NO.	GSA-HYD-0150N-02	REV.	△
SCALE	NONE				

(A4 : 297mm x 210mm)

E0-N0510-QAH-VSD (ON DWG)

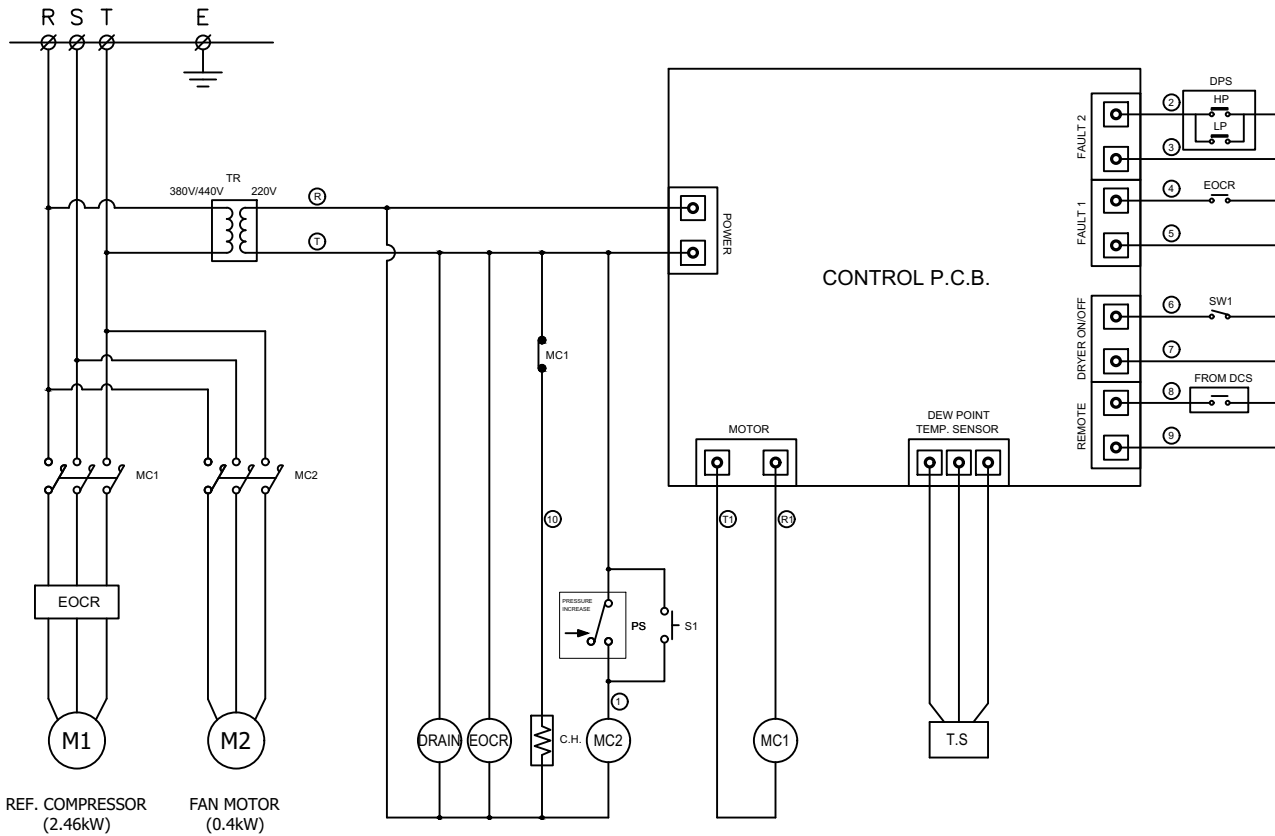

POWER SOURCE AC 380/440V, 3Ph, 50/60Hz		
12	SW1	SYSTEM ON/OFF SWITCH
11	C.H.	COMPRESSOR HEATER
10	DRAIN	AUTO DRAIN VALVE
9	S1	FAN MOTOR TEST BUTTON
8	DPS	DUAL PRESSURE SWITCH
7	T.S	DEW POINT TEMP. SENSOR
6	TR	TRANSFORMER(OPTION)
5	MC1, 2	MAGNETIC CONTACTOR
4	PS	FAN CONTROLLER
3	EOCR	OVERLOAD RELAY
2	M2	FAN MOTOR
1	M1	REF. COMPRESSOR
NO.	SYMBOL	DESCRIPTION

▲																				
▲																				
▲																				
▲																				
▲	2018. 11. 26	ISSUED FOR REFERENCE																		
REV.	DATE	DESCRIPTION	DWG	CHK	APPD	APPD	APPD	APPD	APPD	APPD	APPD	APPD	APPD	APPD	APPD	APPD	APPD	APPD	APPD	APPD
PROJECT																				
MANUFACTURER																				
 <small>Global Standard Air &amp; Gas</small>																				
TITLE																				
WIRING DRAWING																				
ITEM NO.	HYD-150N	DWG NO.	GSA-HYD-0150N-03																	
SCALE	NONE																			