

흡착식 에어드라이어 / 히트레스 Desiccant Air Dryer / Heatless Type

SHL, PHL Series

OPTION

- DEW-POINT METER
- OVER SIZE
- SUS MATERIAL
- HIGH PRESSURE

DESIGN DATA

사용유체(Fluid) : 압축공기(Compressed Air) 노점(DewPoint) : -40°C

입구압력 (Inlet Pressure) 7 bar 입구 온도 (Inlet Temp.) 38°C
 최대사용압력 (Max. Working Pressure) 9.7 bar 주위온도 (Ambient Temp.) 40°C
 차압 (Differential Pressure) 0.2 bar

PRODUCT IMAGE



FLOW DIAGRAM

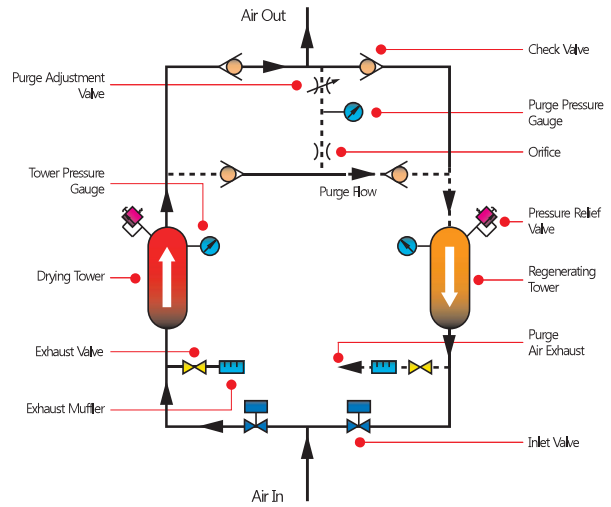

MODEL	접속구경 Connection mm	적용 공기압축기 범위 Air Compressor HP	처리유량 Flow Rate Nm ³ /hr	크기 Dimensions			무게 Weight (Desiccant/Total Weight)	
				A mm	B mm	C mm	흡착제 kg	총 중량 kg
SHL - 5	PT 15A	1	10	500	225	745	3	23
SHL - 10	PT 15A	2	20	500	225	745	4	27
SHL - 15	PT 15A	3	25	500	225	745	7	36
SHL - 20	PT 15A	4	35	500	225	745	10	46
PHL - 25	PT 20A	5	45	840	305	1,010	15	102
PHL - 35	PT 20A	7	60	840	305	1,240	20	123
PHL - 50	PT 20A	10	85	840	305	1,535	25	136
PHL - 75	PT 20A	15	130	1,150	435	1,590	40	160
PHL - 100	PT 25A	20	170	1,150	435	1,760	50	250
PHL - 125	PT 25A	25	215	1,150	435	1,760	60	260
PHL - 150	PT 25A	30	255	1,150	435	1,760	65	272
PHL - 175	PT 40A	35	300	1,150	485	1,760	75	284
PHL - 200	PT 40A	40	340	1,150	485	1,760	90	306
PHL - 250	PT 40A	50	425	1,270	550	1,710	125	405
PHL - 350	PT 40A	70	595	1,270	585	1,820	175	473
PHL - 500	PT 50A	100	870	1,400	670	2,090	250	650
PHL - 650	PT 50A	130	1,110	1,400	745	2,220	325	720
PHL - 800	FLG. 65A	160	1,360	1,500	1,100	2,570	400	900
PHL - 1000	FLG. 80A	200	1,700	1,500	1,100	2,590	500	1,125
PHL - 1200	FLG. 80A	240	2,040	2,095	890	2,370	600	1,305
PHL - 1400	FLG. 80A	280	2,380	2,590	890	2,590	700	1,575
PHL - 1600	FLG. 100A	320	2,720	2,590	950	2,760	800	1,755
PHL - 1800	FLG. 100A	360	3,060	2,590	950	2,760	860	2,205
PHL - 2000	FLG. 100A	400	3,400	2,590	1,060	2,810	1,000	2,340

1. 처리유량은 38°C(100°F), 사용압력 7bar 기준입니다.
2. 노점은 -40°C의 기본 사양이며, -70°C도 공급 가능합니다.
3. 전기사양은 220V 1PH 50/60Hz 입니다.
4. 사양에서 제시된 이상의 대형 기종도 가능합니다.
5. ASME U Stamp 가능.
6. 사양은 품질 개선을 위하여 예고 없이 변경될 수 있습니다.

1. Above flow rate is based on 38°C(100°F) and 7bar.
2. Standard Dew Point is -40°C and -70°C Dew Point products are available.
3. 220V 1PH 50/60Hz is standard.
4. Upon request, customized engineering product is available.
5. ASME U Stamp (Option)
6. The specifications can be changed without notice to improve the quality.

사용 조건이 다를 경우, 해당 조건에 따른 처리유량 변화는 아래의 계수를 처리 유량에 곱해주면 됩니다.
To determine the actual air flow at other conditions, multiply the factors below.

FACTOR

• 입구온도 Inlet Temperature		• 입구압력 Inlet Pressure (bar)	
Temp.	Factor	Press.	Factor
27°C	1.14	2.0	0.40
32°C	1.12	4.0	0.55
38°C	1.00	5.0	0.76
43°C	0.75	7.0	1.00
49°C	0.65	8.0	1.16
		9.0	1.24

DIMENSION(SHL)

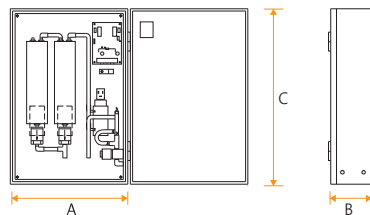

DIMENSION(PHL)

