	Desiccant Air Dryer		Rev.	Date	Prepared By	Checked By	Approved By
			A	2019.01.15	LEE.S.M.	JO.S.J.	KIM.H.W.
	Heatless Type		B				
			C				
			D				
Project No		-		Model Name		PHL-650	
MECHANICAL DESIGN DATA							
2	Supply Voltage	220V		Inlet Flow Rate	1,110		Nm ³ /h
3	Phase	1PH		Inlet Pressure	7.0		barg
4	Frequency	60Hz		Inlet Temp.	38		°C
5	Control use	220V		Outlet Flow Rate	955		Nm ³ /h
6	Fulid	Compressed Air		Outlet Pressure	6.8		barg
7	Location	Indoor		Outlet Temp.	40		°C
8	Design Code	Maker STD.		Pressure Drop	0.2		bar
9	Area Class	Non-Hazardous		Outlet Dew Point	-40		°C at ATM
10	Purge Fulid	Dried Air		Purge Rate	155		Nm ³ /h
CONSTRUCTION							
12	Dryer Type	Heatless		Design Pressure	9.7		barg
13	Vessels Design Code	KS B 6750-3		Design Temperature	250		°C
14	Vessels Corrosion Allowance	1 mm		Ambient Temperature	38		°C
15	Desiccant	Activated Alumina		Drying Time	5		min
16	Desiccant Quantity	325 kg/2Tower		Reactivation Time	4		min
17	Noise	85 dBA		- Heating Time	N/A		min
18	Inlet Connection	50A	PT Female Screw	- Cooling Time	N/A		min
19	Outlet Connection	50A	PT Female Screw	- Repressing Time	1		min
20	Material			Heater Type	Location	N/A	
21	- Shell / Head	SPP / SS275			Method	N/A	
22	- Flange / Pipe	SS275 / SPP		Heater Power	Main	N/A	kW
23	- Heater(Shell/Head)	N/A			Aux.	N/A	kW
24	Dimension (W x L x H)	1400 X 745 X 2220 mm		Control Panel Power	50		W
25	Weight	720 kg		Blower Power	N/A		kW
26	Color (Munsell)	3.0 BG 7.1/0.2		Power Consumption(Avg.)	50		W
27	Insulation	NO		Control Unit	Printed Circuit Board (P.C.B)		
28				Enclosure Control Panel	IP23		
INSTRUMENTS-ACESSORIES							
30	Pressure Gauge	YES					
31	Pressure Switch	NO					
32	Orifice	YES					
33	Pressure Regulator For Control Air	NO					
34	Instrument Air Filter	YES					
35							
OPTION ITEM							
37	Touch Screen	NO					
38	Valve Limit Switch	NO					
39	Dew Point Meter	NO					
40	Local Control Panel Double Door	NO					
41	Anchor Bolt / Nut	NO					
NOTES							
43							
44							
45							
46							

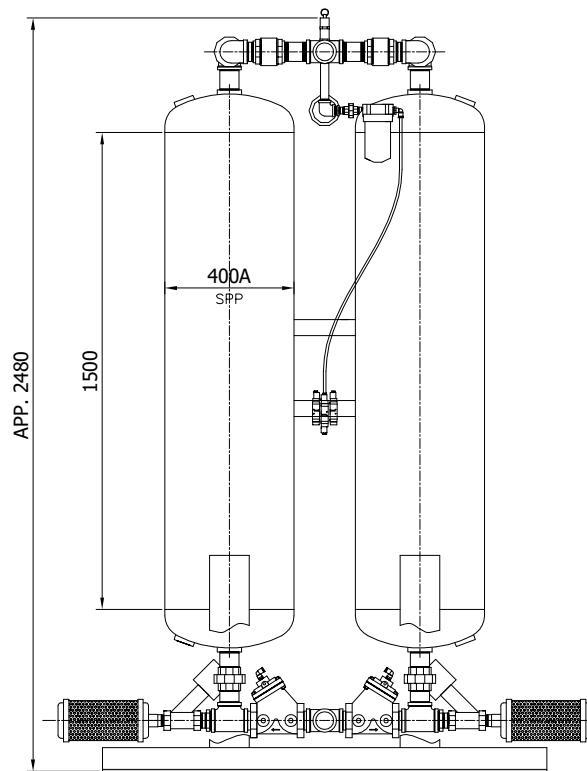

POWER SOURCE AC 220V, 1Ph, 50/60Hz			
NO.	PART NAME	DESC.	QTY
19	OUTLET	PT 50A	1
18	INLET	PT 50A	1
17	CONTROL BOARD	PCB	1
16	ENCLOSURE	-	1
15	DESICCANT TOWER	-	2
14	PURGE EXH. SOL. V/V	-	2
13	PURGE EXH. V/V	PT 40A	2
12	PURGE EXH. MUFFLER	PT 40A	2
11	INLET VALVE	PT 50A	2
10	TOWER SELECTING SOL. V/V	4W 2P	1
9	PRESSURE RELIEF V/V	PT 32A	1
8	POWER ON/OFF SWITCH	250V 6A	1
7	INSTRUMENT AIR FILTER	PT 10A	1
6	PURGE PRESSURE GAUGE	PT 8A	1
5	PURGE ORIFICE UNION	PT 20A	1
4	PURGE ADJUSTING V/V	PT 20A	1
3	TOWER PRES. GAUGE	PF 8A	2
2	PURGE CHECK V/V	PT 20A	2
1	OUTLET CHECK V/V	PT 50A	2

△										
△										
△										
△										
△										
△	2018.12.10	ISSUED FOR PROPOSAL	-	-	-	-	-	-	-	
REV. NO.	DATE	DESCRIPTION	DWG	CHK	APPD	APPD	APPD	APPD		
PROJECT										
MANUFACTURER										
TITLE										
PHL-650 OUTLINE										
ITEM NO.	PHL-650	DWG NO.								REV.
SCALE	NONE	GSA-PHL-0650-01							△	

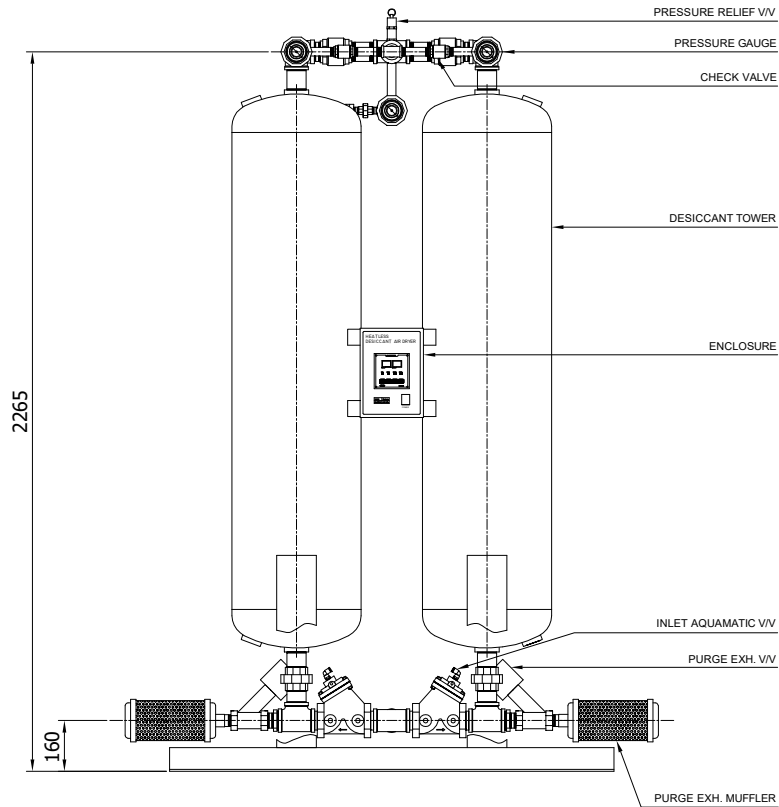
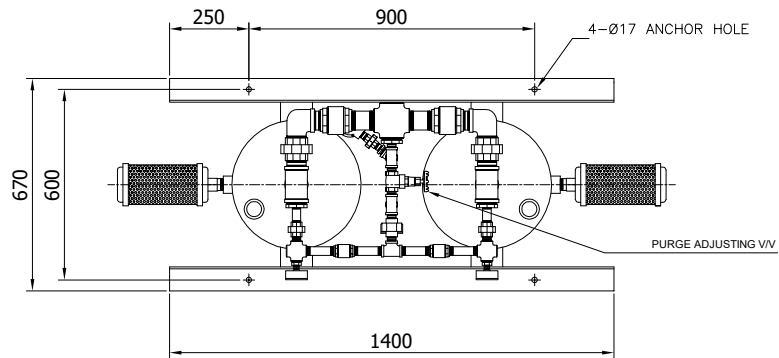
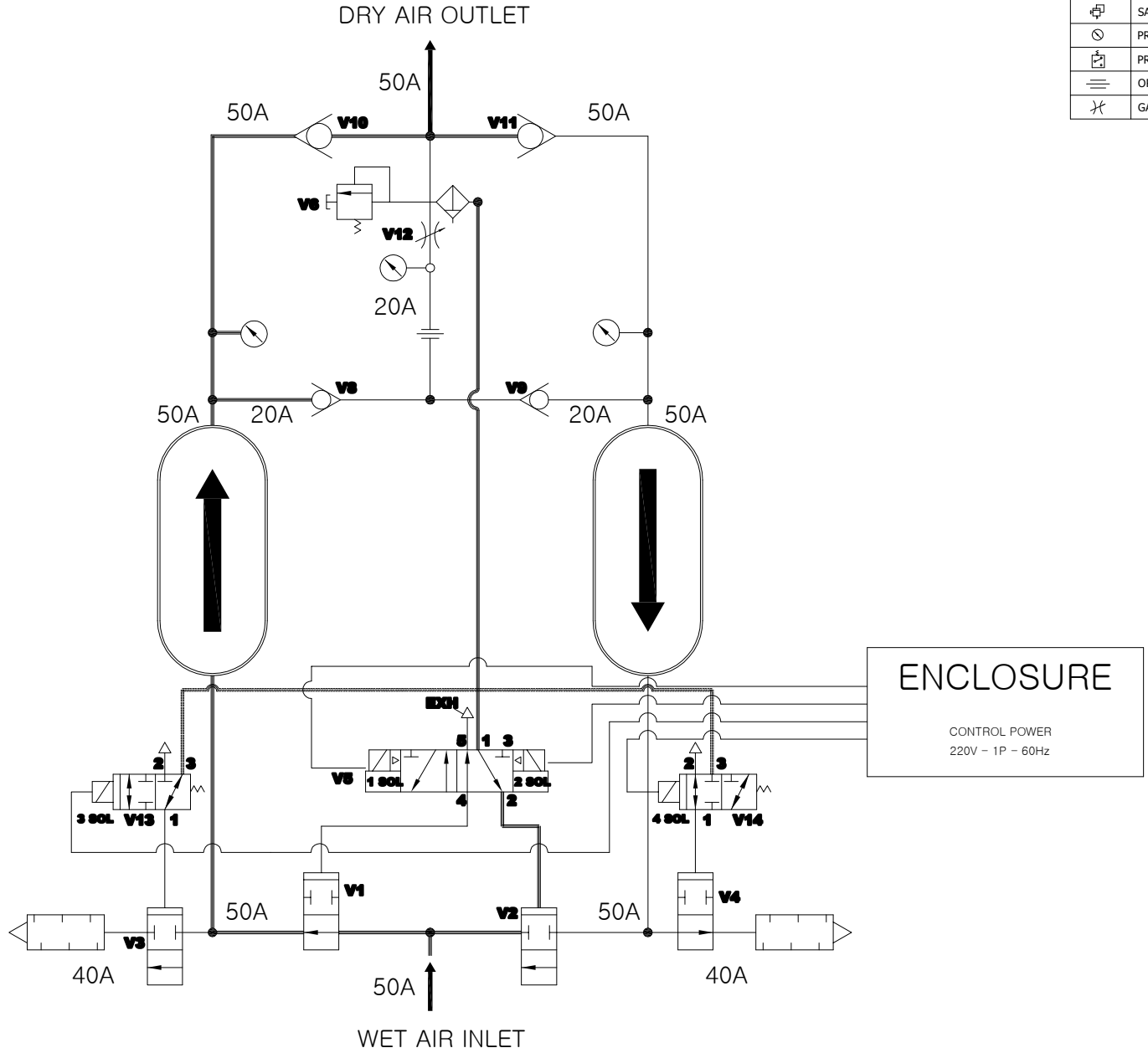

SYMBOL	DESCRIPTION	NO.	NOTE
	CHECK VALVE	1	LINE SYMBOLS FOR FLOW DIRECTION. — LEFT TOWER DRYING — RIGHT TOWER REGENERATING — PILOT AIR LINE — ELECTRIC CONNECTION
	MUFFLER	2	
	SAFETY VALVE	3	
	PRESSURE GAUGE		
	PRESSURE SWITCH		
	ORIFICE		
	GATE VALVE		

* 18	D.P. SENSOR ISOLATION VALVE(V14)
* 17	DEW POINT SENSOR ASSEMBLY
* 16	D.P. SENSOR PREFILTER
* 15	D.P. SENSOR ISOLATION VALVE(V13)
14	PURGE EXH. PILOT SOLENOID VALVE
13	DESICCANT TOWERS
12	AIR FILTER FOR VALVE CONTROL
11	PURGE FLOW ADJUSTMENT VALVE(V12)
10	PURGE FLOW ORIFICE
9	PURGE PRESSURE GAUGE
8	TOWER PRESSURE GAUGES
7	OUTLET CHECK VALVE(V10/V11)
6	PURGE CHECK VALVE(V8/V9)
5	TOWER SAFETY VALVE(V6/V7)
4	TOWER SELECTING VALVE(V5)
3	PURGE EXHAUST MUFFLER
2	PURGE EXHAUST VALVE(V3/V4)
1	INLET VALVE(V1/V2)
NO.	DESCRIPTION

ENCLOSURE

CONTROL POWER
220V - 1P - 60Hz

△									
△									
△									
△									
△									
△	2018.12.10	ISSUED FOR PROPOSAL	-	-	-	-	-	-	-
REV. NO.	DATE	DESCRIPTION	ENWG	CHK	APPD	APPD	APPD	APPD	APPD
PROJECT									
MANUFACTURER									
TITLE									
PHL-650 SYSTEM									
ITEM NO.	PHL-650	DWG NO.							
SCALE	NONE	GSA-PHL-0650-02							
(A1 : 841mm x 594mm)									

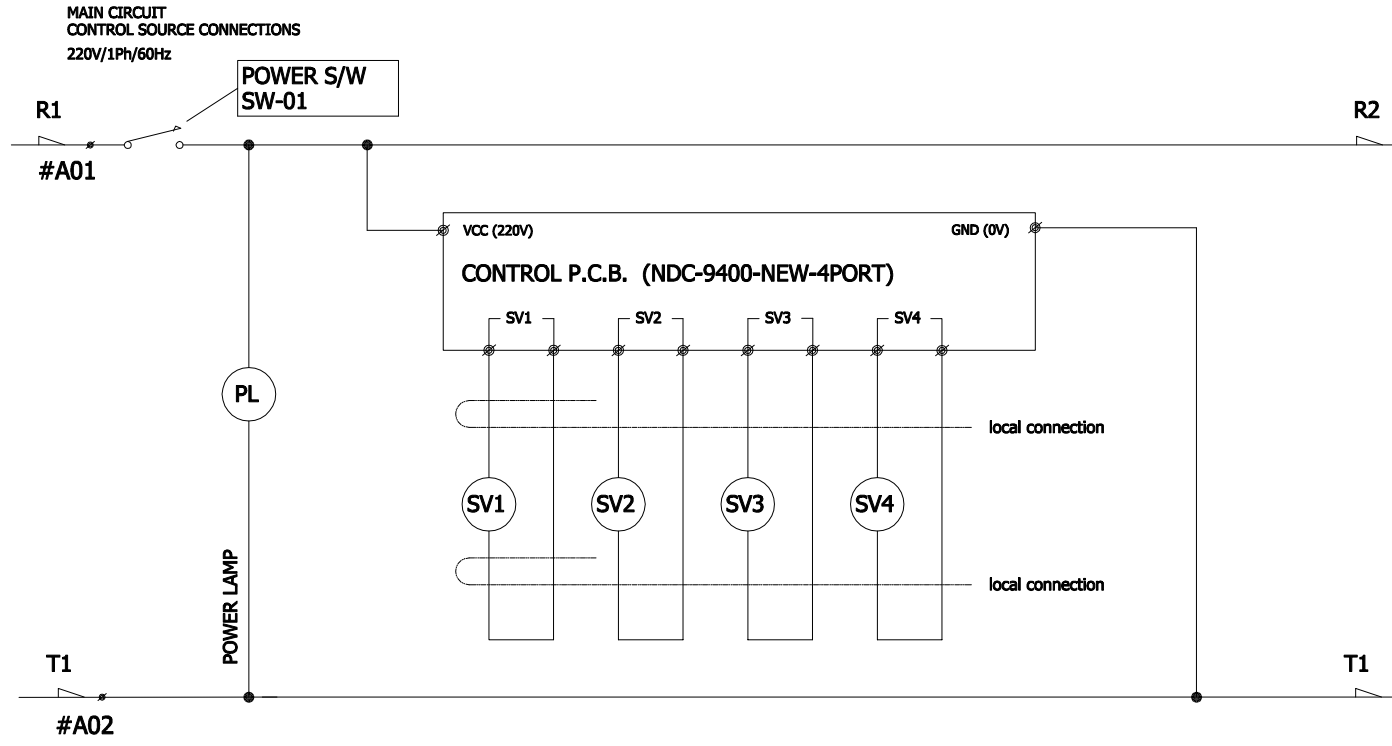

SV1	B-TOWER INLET
SV2	B-TOWER PURGE
SV3	A-TOWER INLET
SV4	A-TOWER PURGE

△									
△									
△									
△									
△	2018.12.10	ISSUED FOR PROPOSAL	-	-	-	-	-	-	-
REV. NO.	DATE	DESCRIPTION	DWG	CHK	APPD	APPD	APPD	APPD	APPD
PROJECT									
MANUFACTURER									
 Global Standard Air & Gas									
TITLE									
PHL-650 WIRING									
ITEM NO.	PHL-650	DWG NO.		REV.					
SCALE	NONE	GSA-PHL-0650-03		△					