		Desiccant Air Dryer Heatless Type		Rev.	Date	Prepared By	Checked By	Approved By
				1	2019.01.15	LEE.S.M.	JO.S.J.	KIM.H.W.
Project No		-		Model Name		PHL-1600		
MECHANICAL DESIGN DATA								
2	Supply Voltage	220V		Inlet Flow Rate	2,720		Nm ³ /h	
3	Phase	1PH		Inlet Pressure	7.0		barg	
4	Frequency	60Hz		Inlet Temp.	38		°C	
5	Control use	220V		Outlet Flow Rate	2,339		Nm ³ /h	
6	Fulid	Compressed Air		Outlet Pressure	6.8		barg	
7	Location	Indoor		Outlet Temp.	40		°C	
8	Design Code	Maker STD.		Pressure Drop	0.2		bar	
9	Area Class	Non-Hazardous		Outlet Dew Point	-40		°C at ATM	
10	Purge Fulid	Dried Air		Purge Rate	381		Nm ³ /h	
CONSTRUCTION								
12	Dryer Type	Heatless		Design Pressure	9.7		barg	
13	Vessels Design Code	KS B 6750-3		Design Temperature	250		°C	
14	Vessels Corrosion Allowance	1 mm		Ambient Temperature	38		°C	
15	Desiccant	Activated Alumina		Drying Time	5		min	
16	Desiccant Quantity	800 kg/2Tower		Reactivation Time	4		min	
17	Noise	85 dBA		- Heating Time	N/A		min	
18	Inlet Connection	100A	KS 10K SO.FF.	- Cooling Time	N/A		min	
19	Outlet Connection	100A	KS 10K SO.FF.	- Repressing Time	1		min	
20	Material			Heater Type	Location	N/A		
21	- Shell / Head	SS275 / SS275			Method	N/A		
22	- Flange / Pipe	SS275 / SPP		Heater Power	Main	N/A	kW	
23	- Heater(Shell/Head)	N/A			Aux.	N/A	kW	
24	Dimension (W x L x H)	2590 X 1000 X 2730 mm		Control Panel Power	50		W	
25	Weight	1,755 kg		Blower Power	N/A		kW	
26	Color (Munsell)	3.0 BG 7.1/0.2		Power Consumption(Avg.)	50		W	
27	Insulation	NO		Control Unit	Printed Circuit Board (P.C.B)			
28				Enclosure Control Panel	IP23			
INSTRUMENTS-ACESSORIES								
30	Pressure Gauge	YES						
31	Pressure Switch	NO						
32	Orifice	YES						
33	Pressure Regulator For Control Air	NO						
34	Instrument Air Filter	YES						
35								
OPTION ITEM								
37	Touch Screen	NO						
38	Valve Limit Switch	NO						
39	Dew Point Meter	NO						
40	Local Control Panel Double Door	NO						
41	Anchor Bolt / Nut	NO						
NOTES								
43								
44								
45								
46								

POWER SOURCE
AC 220V, 1Ph, 50/60Hz

NO.	PART NAME	DESC.	QTY
19	OUTLET	FLG. 100A	1
18	INLET	FLG. 100A	1
17	CONTROL BOARD	PCB	1
16	ENCLOSURE	-	1
15	DESICCANT TOWER	-	2
14	PURGE EXH. SOL. V/V	-	2
13	PURGE EXH. V/V	PT 50A	2
12	PURGE EXH. MUFFLER	PT 50A	2
11	INLET BUTTERFLY VALVE	FLG. 100A	2
10	TOWER SELECTING SOL. V/V	4W 2P	1
9	PRESSURE RELIEF VALVE	FLG. 32A	1
8	POWER ON/OFF SWITCH	250V 6A	1
7	INSTRUMENT AIR FILTER	PT 15A	1
6	PURGE PRESSURE GAUGE	PT 8A	1
5	PURGE ORIFICE UNION	PT 40A	1
4	PURGE ADJUSTMENT VALVE	PT 40A	1
3	TOWER PRESSURE GAUGE	PF 8A	2
2	PURGE CHECK VALVE	PT 40A	2
1	OUTLET CHECK VALVE	FLG. 100A	2

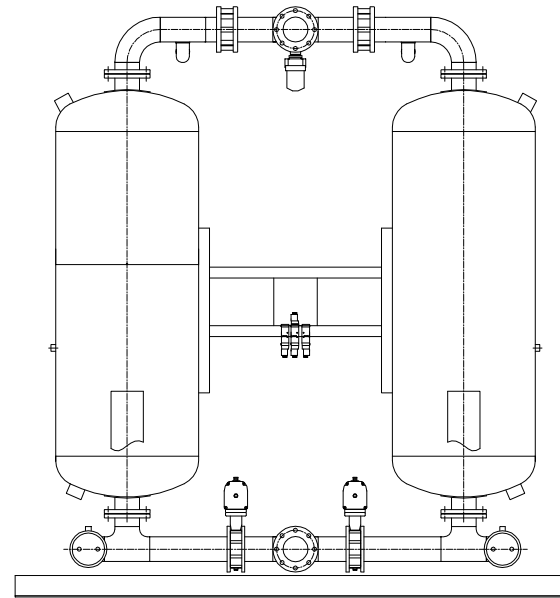
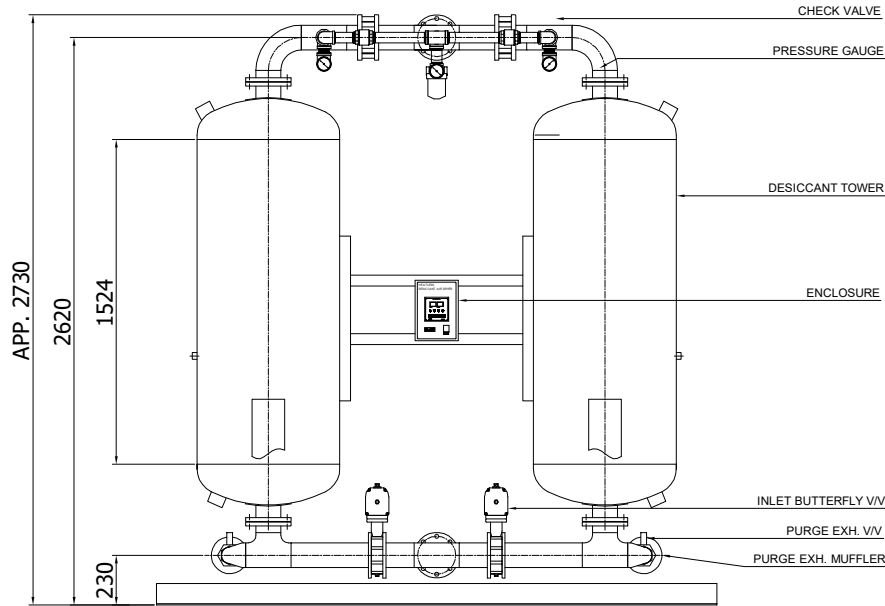
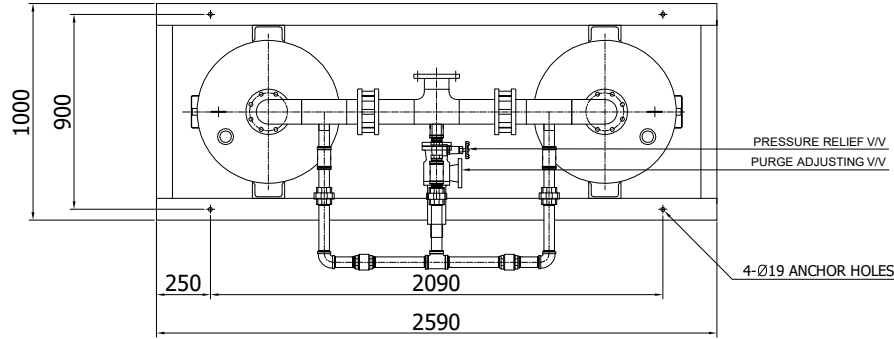

REV. NO.	DATE	DESCRIPTION	DWG	CHK	APPD	APPD	APPD
△							
△							
△							
△							
△	2018.12.10	ISSUED FOR PROPOSAL	-	-	-	-	-

PROJECT: -

MANUFACTURER: **GSA**
Global Standard Air & Gas

TITLE: **PHL-1600 OUTLINE**

ITEM NO.	PHL-1600	DWG NO.		REV.	△
SCALE	NONE	GSA-PHL-1600-01			

SYMBOL	DESCRIPTION
	CHECK VALVE
	MUFFLER
	SAFETY VALVE
	PRESSURE GAUGE
	PRESSURE SWITCH
	ORIFICE
	GATE VALVE

NO.	NOTE
1	LINE SYMBOLS FOR FLOW DIRECTION. — LEFT TOWER DRYING — RIGHT TOWER REGENERATING — PILOT AIR LINE — ELECTRIC CONNECTION
2	SOLENOID VALVES 1SOL AND 4SOL ARE SHOWN ENERGIZED. SOLENOID VALVES 2SOL AND 3SOL ARE SHOWN DE-ENERGIZED.
3	"**" INDICATES OPTIONAL PARTS FOR HIGH D.P. ALARM OR DEMAND CYCLE.

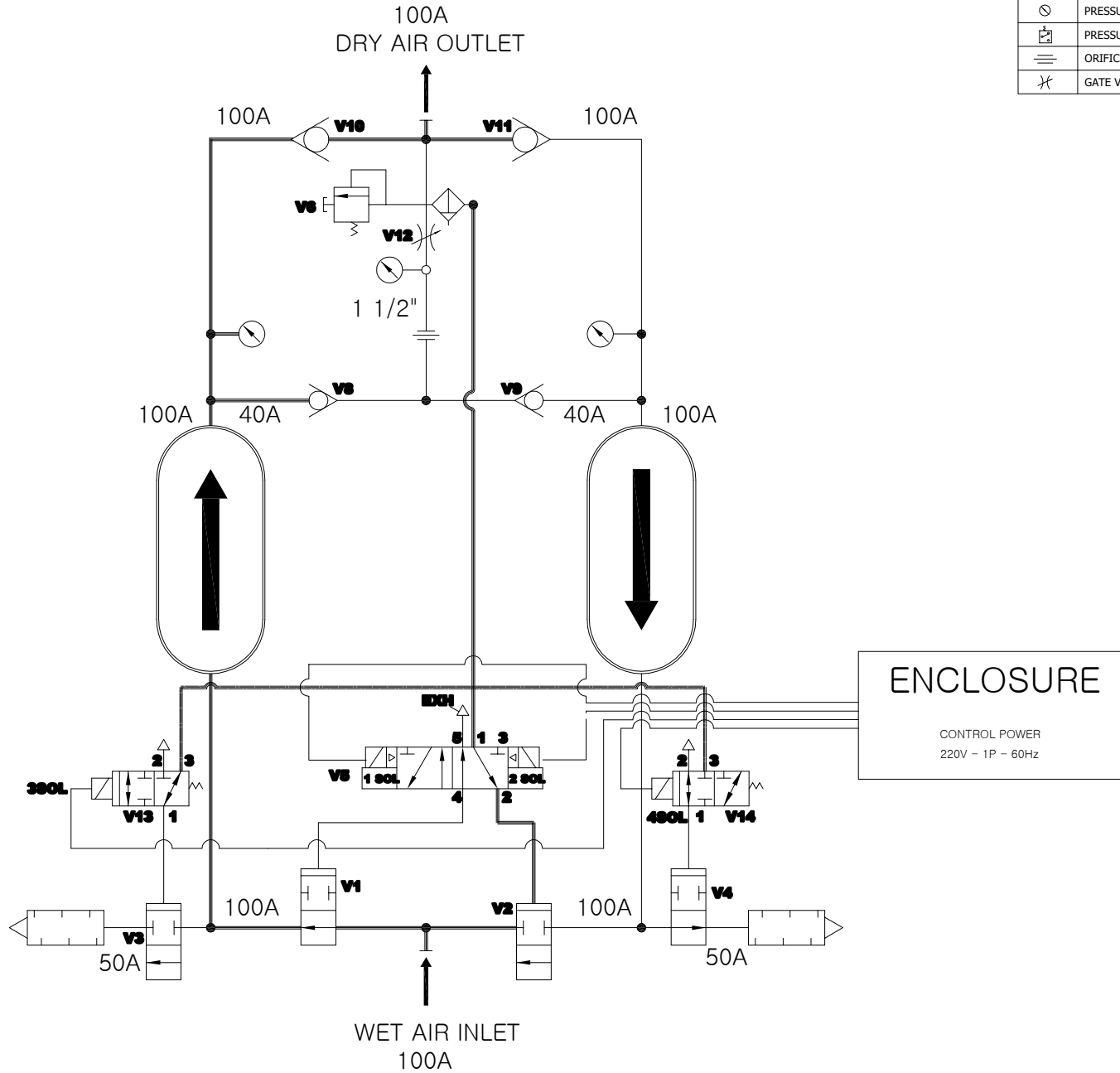

* 18	D.P. SENSOR ISOLATION VALVE(V14)
* 17	DEW POINT SENSOR ASSEMBLY
* 16	D.P. SENSOR PREFILTER
* 15	D.P. SENSOR ISOLATION VALVE(V13)
14	PURGE EXH. PILOT SOLENOID VALVE
13	DESICCANT TOWERS
12	AIR FILTER FOR VALVE CONTROL
11	PURGE FLOW ADJUSTMENT VALVE(V12)
10	PURGE FLOW ORIFICE
9	PURGE PRESSURE GAUGE
8	TOWER PRESSURE GAUGES
7	OUTLET CHECK VALVE(V10/V11)
6	PURGE CHECK VALVE(V8/V9)
5	TOWER SAFETY RELIEF VALVE(V6/V7)
4	TOWER SELECTING SOL. VALVE(V5)
3	PURGE EXHAUST MUFFLER
2	PURGE EXHAUST VALVE(V3/V4)
1	INLET VALVE(V1/V2)
NO.	DESCRIPTION

ENCLOSURE

CONTROL POWER
220V - 1P - 60Hz

△										
△										
△										
△										
△										
△	2018.12.10	ISSUED FOR PROPOSAL	-	-	-	-	-	-	-	
REV. NO.	DATE	DESCRIPTION	DWG	CHK	APPD	APPD	APPD	APPD		
PROJECT										
MANUFACTURER										
TITLE										
PHL-1600 SYSTEM										
ITEM NO.	PHL-1600	DWG NO.								REV.
SCALE	NONE	GSA-PHL-1600-02								

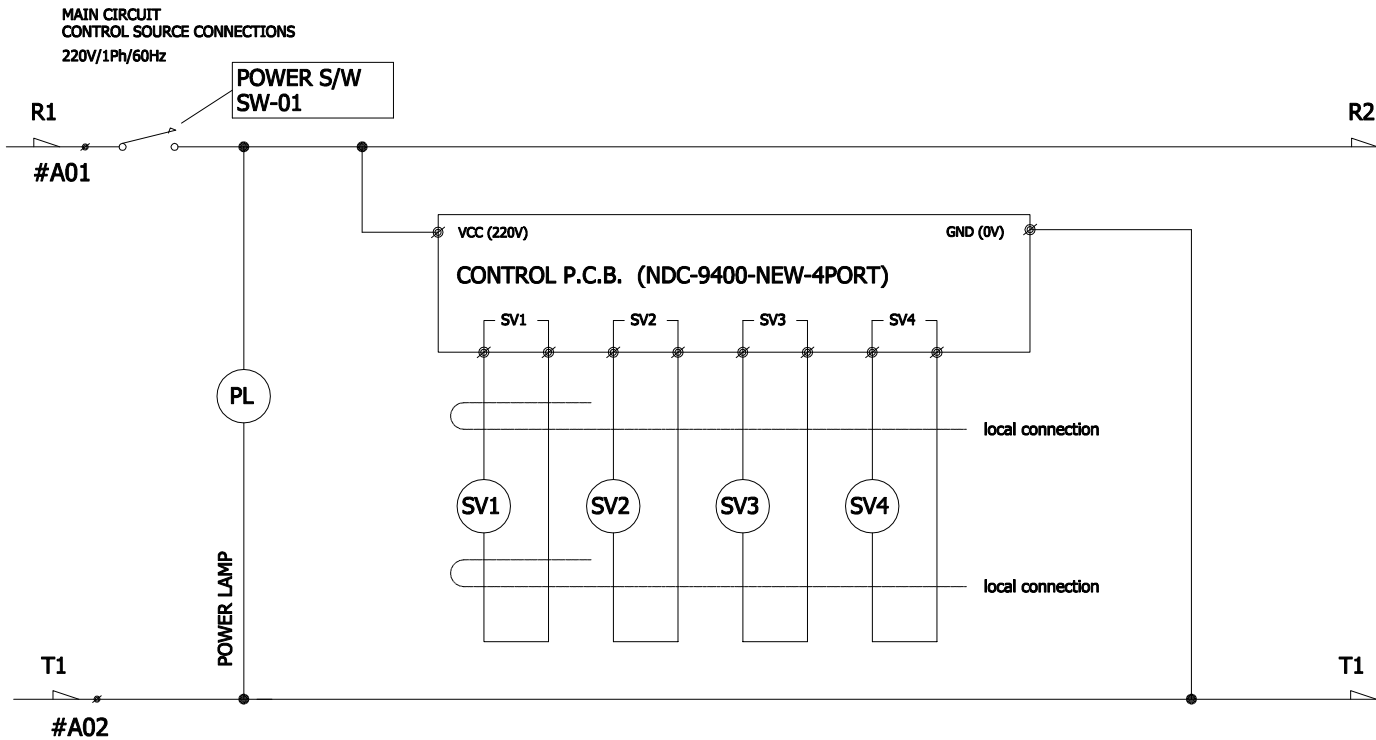

SV1	B-TOWER INLET
SV2	B-TOWER PURGE
SV3	A-TOWER INLET
SV4	A-TOWER PURGE

△										
△										
△										
△										
△										
△	2018.12.10	ISSUED FOR PROPOSAL	-	-	-	-	-	-	-	
REV. NO.	DATE	DESCRIPTION	DWG	CHK	APPD	APPD	APPD	APPD	APPD	
PROJECT										
MANUFACTURER										
 Global Standard Air & Gas										
TITLE										
PHL-1600 WIRING										
ITEM NO.	PHL-1600	DWG NO.								REV.
SCALE	NONE	GSA-PHL-1600-03							△	