		Desiccant Air Dryer Heater Purge Type		Rev.	Date	Prepared By	Checked By	Approved By
				1	2019.01.15	LEE.S.M.	JO.S.J.	KIM.H.W.
Project No		-		Model Name		PEH-1550		
MECHANICAL DESIGN DATA								
2	Supply Voltage	380V		Inlet Flow Rate	2,950		Nm ³ /h	
3	Phase	3PH		Inlet Pressure	7.0		barg	
4	Frequency	60Hz		Inlet Temp.	38		°C	
5	Control use	220V		Outlet Flow Rate	2,714		Nm ³ /h	
6	Fulid	Compressed Air		Outlet Pressure	6.8		barg	
7	Location	Indoor		Outlet Temp.	40		°C	
8	Design Code	Maker STD.		Pressure Drop	0.2		bar	
9	Area Class	Non-Hazardous		Outlet Dew Point	-40		°C at ATM	
10	Purge Fulid	Dried Air		Purge Rate	236		Nm ³ /h	
CONSTRUCTION								
12	Dryer Type	Heater		Design Pressure	9.7		barg	
13	Vessels Design Code	KS B 6750-3		Design Temperature	250		°C	
14	Vessels Corrosion Allowance	1 mm		Ambient Temperature	38		°C	
15	Desiccant	Activated Alumina		Drying Time	240		min	
16	Desiccant Quantity	1,050 kg/2Tower		Reactivation Time	240		min	
17	Noise	85 dBA		- Heating Time	150		min	
18	Inlet Connection	100A	KS 10K SO.FF.	- Cooling Time	87		min	
19	Outlet Connection	100A	KS 10K SO.FF.	- Repressing Time	3		min	
20	Material			Heater Type	Location	External		
21	- Shell / Head	SS275 / SS275			Method	Electric.		
22	- Flange / Pipe	SS275 / SPP		Heater Power	Main	21.6	kW	
23	- Heater(Shell/Head)	SPP / SS275			Aux.	7.2	kW	
24	Dimension (W x L x H)	1900 X 1400 X 2805 mm		Control Panel Power	0.2		kW	
25	Weight	3,000 kg		Blower Power	N/A		kW	
26	Color (Munsell)	3.0 BG 7.1/0.2		Power Consumption(Avg.)	18.2		kW	
27	Insulation	NO		Control Unit	Programmable Logic Controller (P.L.C)			
28				Enclosure Control Panel	IP23			
INSTRUMENTS-ACCESSORIES								
30	Pressure Gauge	YES		Temperature Controller	YES			
31	Temperature Gauge	YES		Pressure Switch	YES			
32	Thermocouple	YES						
33	Pressure Regulator For Control Air	YES						
34	Instrument Air Filter	YES						
35	Orifice	YES						
OPTION ITEM								
37	Touch Screen	NO		Anchor Bolt / Nut	NO			
38	Valve Limit Switch	NO						
39	Dew Point Meter	NO						
40	Local Control Panel Double Door	NO						
41	Thyristor Power Regulator (S.C.R)	NO						
NOTES								
43								
44								
45								
46								

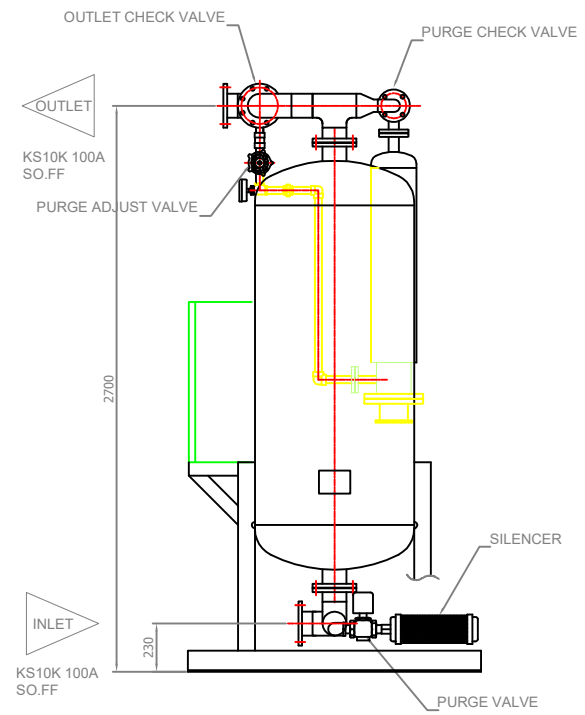
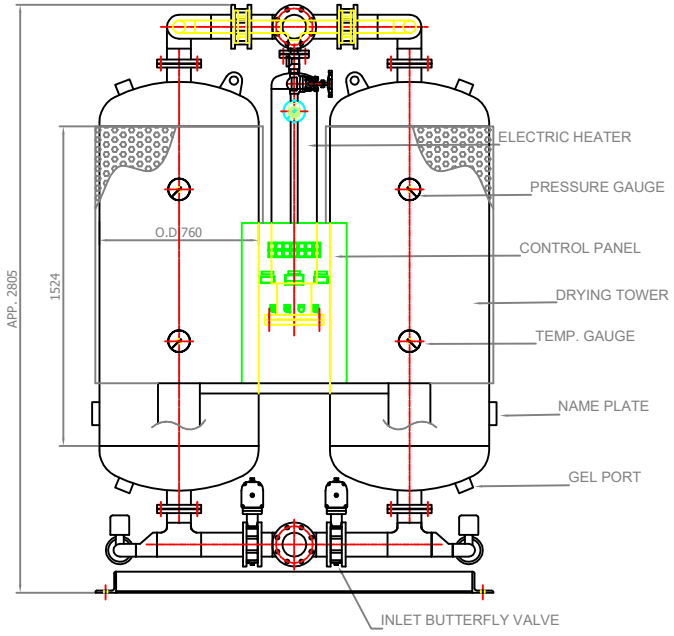
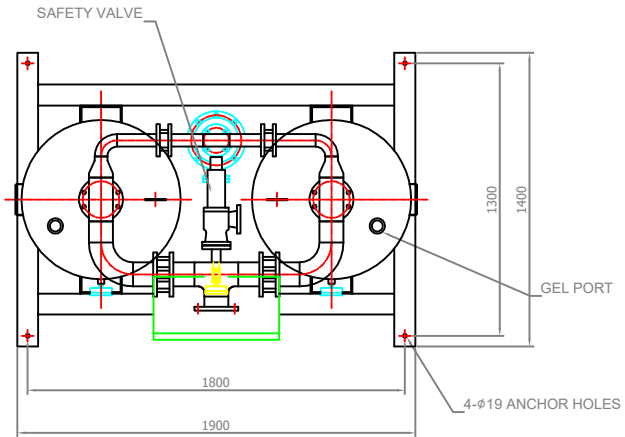

NO	DESCRIPTION	MATL	QTY	SPECIFICATION
1	ELECTRIC HEATER	-	1	28.8 kW
2	INLET BUTTERFLY VALVE	FCD	2	FLANGE 4"
3	OUTLET CHECK VALVE	BRASS	2	FLANGE 4"
4	PURGE CHECK VALVE	304	2	FLANGE 2"
5	PURGE VALVE	304	2	PT 2"
6	SILENCER	-	2	PT 2"
7	PRESSURE GAUGE	C.S	3	15bar -100
8	TEMPERATURE GAUGE	C.S	2	250°C -100
9	GEL PORT	-	2	PT 2"
10	GEL PORT	-	2	PT 2"
11	SAFETY VALVE	C.S	1	FLANGE 1 1/4"
12	NAME PLATE	AL	2	-
13	DRYING TOWER	SS400	2	-
14	PURGE ADJUST VALVE	A105	1	PT 1"
15	A - TOWER INLET VALVE	-	1	-
16	B - TOWER INLET VALVE	-	1	-
17	A - TOWER PURGE VALVE	-	1	-
18	B - TOWER PURGE VALVE	-	1	-
19	CONTROL PANEL	-	-	-

SPECIFICATION			
1	PROCESS	COMPRESSED AIR	
2	CAPACITY	2950	Nm ³ /hr
3	INLET AIR PRESSURE	7	barg
4	INLET AIR TEMPERATURE	38	°C
5	DESIGN PRESSURE	9.7	barg
6	DEW POINT	-40	°C
7	NORMAL PURGE	236	Nm ³ /hr
8	POWER SUPPLY	380V-3PH-60HZ	
9	CONTROL POWER	220V-1PH-60HZ	
10	CYCLE TIME	4 + 4 HOURS	
11	DESICCANT	1050	kg/2TOWER
12	HEATER	28.8	kW
13	COLOR	3.OBG 7.1/0.2	
14	WEIGHT	3000	kg

REVISION			
REV.	DESCRIPTION	DATE	DWG. BY

△									
△									
△									
△									
△									
△									
△									
△									
△									
△	2018.12.10	ISSUED FOR PROPOSAL	-	-	-	-	-	-	-
REV.	DATE	DESCRIPTION	DWG	CHK	APPD	APPD	APPD	APPD	APPD
PROJECT									

MANUFACTURER

TITLE

PEH-1550 OUTLINE

ITEM NO.	PEH-1550	DWG NO.		REV.	△
SCALE	NONE				

1 (A1 : 841mm x 594mm)

SYMBOL	DESCRIPTION		REDUCING VALVE	—	AIR MAIN LINE	DT	DRYER TOWER	NV	NEEDLE VALVE
	BALL VALVE (NOR.OPEN)		SAFETY VALVE		INSTRUMENT AIR LINE	OF	ORIFICE	CV	CHECK VALVE
	BALL VALVE (NOR.CLOSE)		SOLENOID VALVE (SINGLE)		ELECTRIC LINE	TS	THERMOSTAT	GBV	GLOBE VALVE
	GLOBE VALVE		SOLENOID VALVE (DOUBLE)	TI	TEMPERATURE GAUGE	SV	SOLENOID VALVE	SFV	SAFETY VALVE
	NEEDLE VALVE		BUTTERFLY VALVE	PI	PRESSURE GAUGE	PV	PURGE VALVE		
	CHECK VALVE		AUTO DRAIN TRAP	EH	ELECTRIC HEATER	FRL	AIR UNIT		
	GATE VALVE		LUB. OIL LINE	BV	BUTTERFLY VALVE	MF	SILENCER		

DESIGN DATA		
NO	DESCRIPTIONS	SPECIFICATIONS
01	MODEL NO.	PEH-1550
02	APPLICATION FLUID	COMPRESSED AIR
03	FLOW RATE	2950 Nm ³ /hr
04	OUTLET DEW POINT	-40 °C @ ATM
05	INLET AIR PRESSURE	7.0 barg
06	INLET AIR TEMP.	38 °C
07	DRY/REGEN. CYCLE	4 HOURS + 4 HOURS
08	DESIGN PRESSURE	9.7 barg
09	DESIGN TEMP.	250 °C
10	HYDRAULIC TEST PR.	15 barg
11	INLET NOZZLE	100A KS 10K SO. FF.
12	OUTLET NOZZLE	100A KS 10K SO. FF.
13	ELECTRICITY	380V/3Ph/60Hz
14	VESSELS	DUAL/VERTICALLY ELEVATED.
15	DESICCANT	ACTIVATED ALUMINA
16	ACTIVATED ALUMINA	1050 kg/2Tower
17	SIZE OF HEATER	28.8 KW

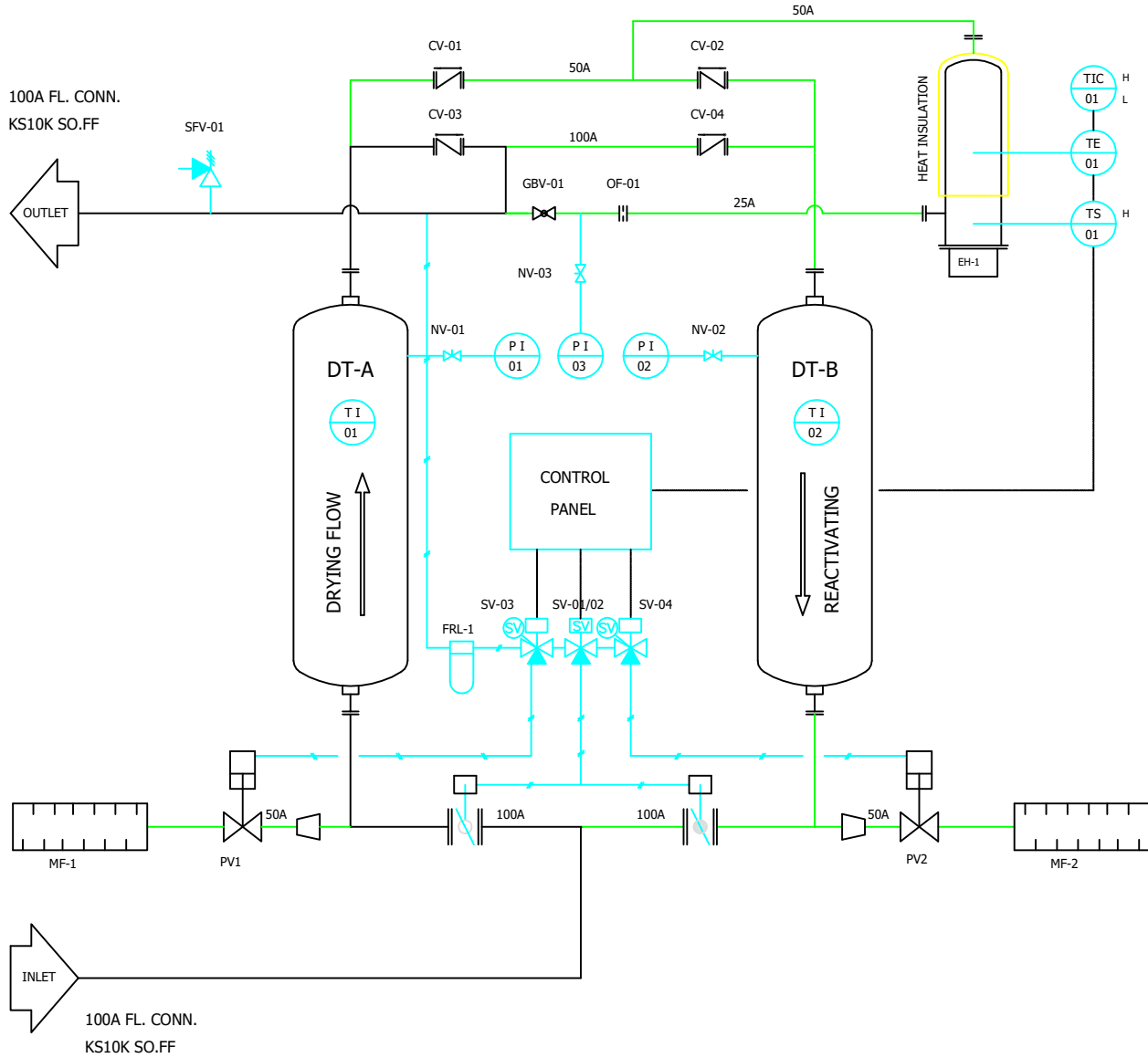

△										
△										
△										
△										
△										
△	2018.12.10	ISSUED FOR PROPOSAL								
REV.	DATE	DESCRIPTION	DWG	CHK	APPD	APPD	APPD	APPD		
PROJECT										
MANUFACTURER										
TITLE										
PEH-1550 SYSTEM										
ITEM NO.	PEH-1550	DWG NO.								REV.
SCALE	NONE	GSA-PEH-1550-02								

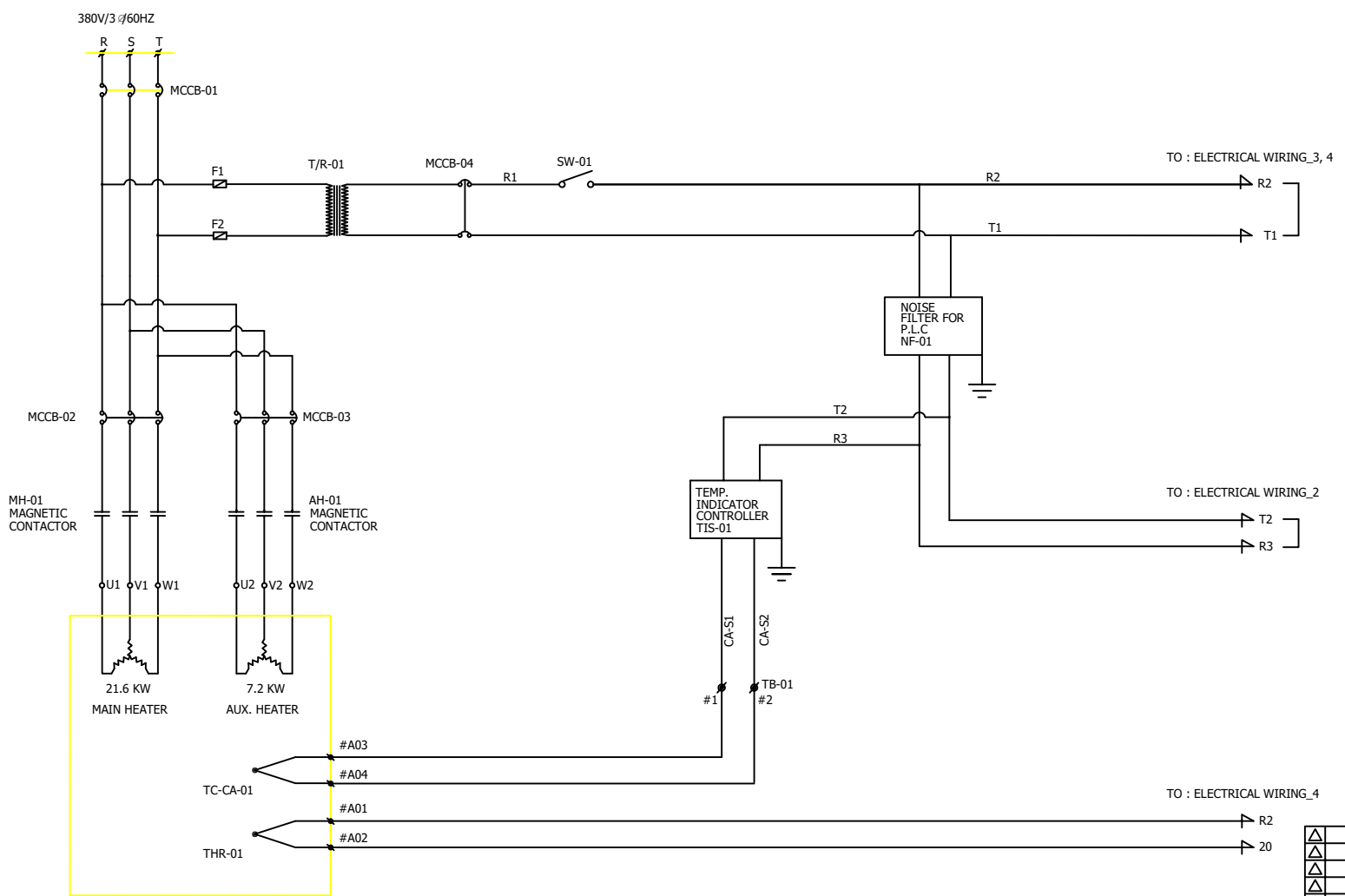

△										
△										
△										
△										
△	2018.12.10	ISSUED FOR PROPOSAL	-	-	-	-	-	-	-	
REV.	DATE	DESCRIPTION	EWG	CHK	APPD	APPD	APPD	APPD	APPD	
PROJECT										
MANUFACTURER										
 Global Standard Air & Gas										
TITLE										
PEH-1550 WIRING										
ITEM NO.	PEH-1550	DWG NO.		GSA-PEH-1550-03						REV.
SCALE	NONE									△

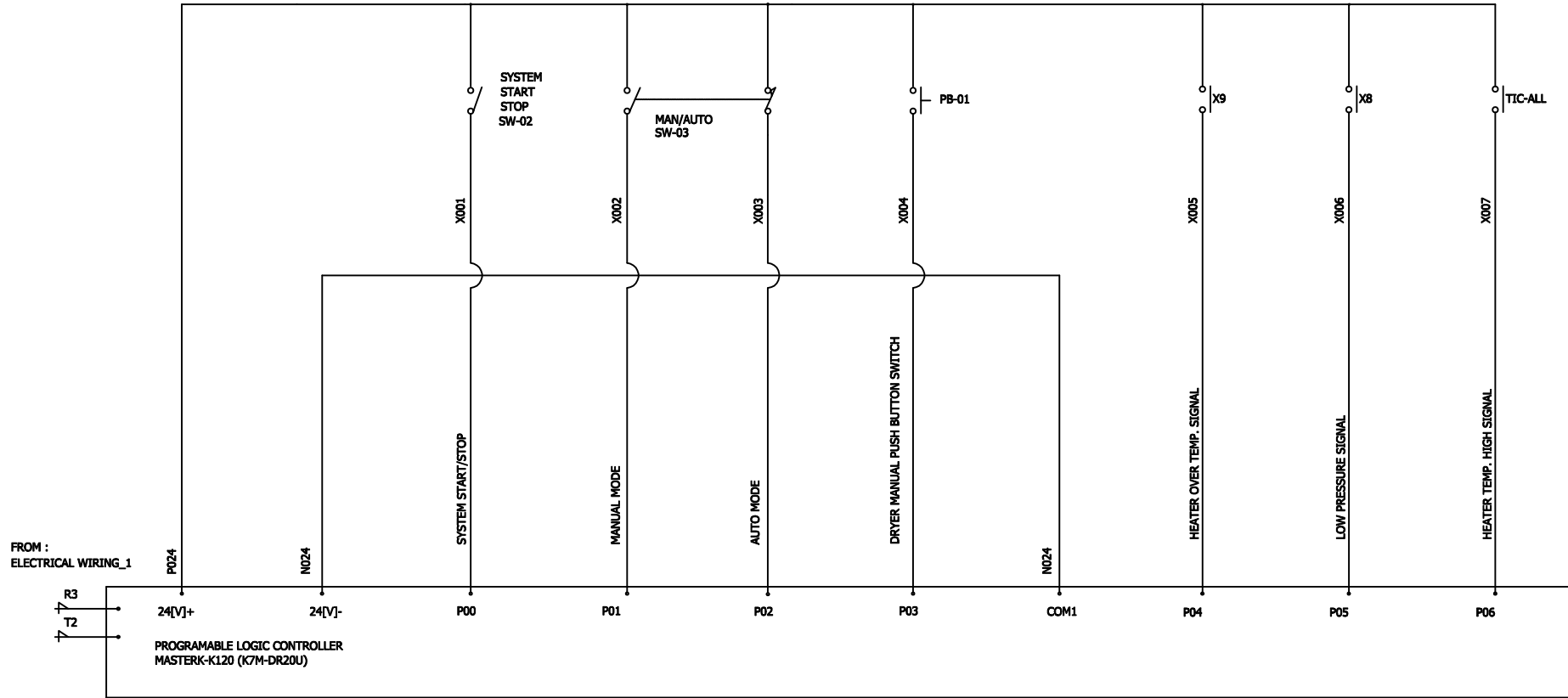

△										
△										
△										
△										
△										
△	2018.12.10	ISSUED FOR PROPOSAL	-	-	-	-	-	-	-	
REV.	DATE	DESCRIPTION	EWG	CHK	APPD	APPD	APPD	APPD	APPD	
PROJECT										
MANUFACTURER										
										
TITLE										
PEH-1550 WIRING										
ITEM NO.	PEH-1550	DWG NO.		GSA-PEH-1550-04						REV.
SCALE	NONE									△

FROM : ELECTRICAL WIRING_1

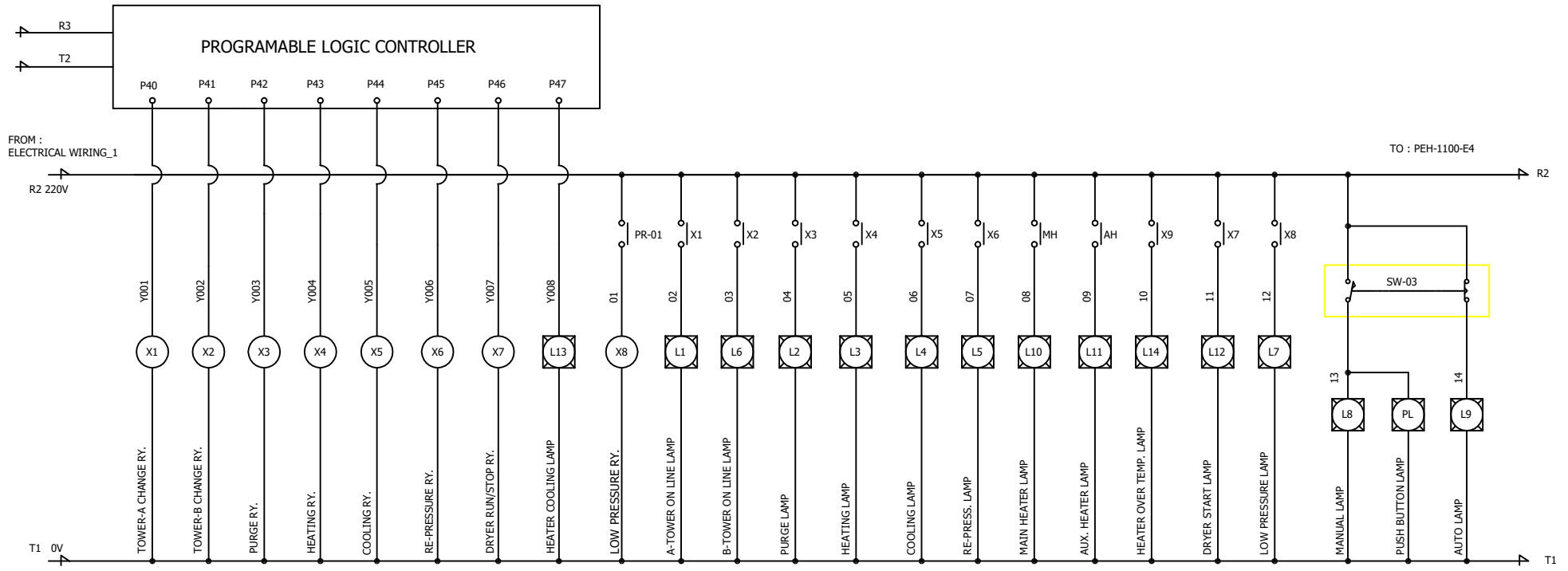

TO : PEH-1100-E4

△										
△										
△										
△										
△	2018.12.10	ISSUED FOR PROPOSAL	-	-	-	-	-	-	-	
REV.	DATE	DESCRIPTION	ENGR	CHK	APPD	APPD	APPD	APPD	APPD	
PROJECT										
MANUFACTURER										
TITLE										
PEH-1550 WIRING										
ITEM NO.	PEH-1550	DWG NO.								REV.
SCALE	NONE	GSA-PEH-1550-05							△	

FROM : ELECTRICAL WIRING_1

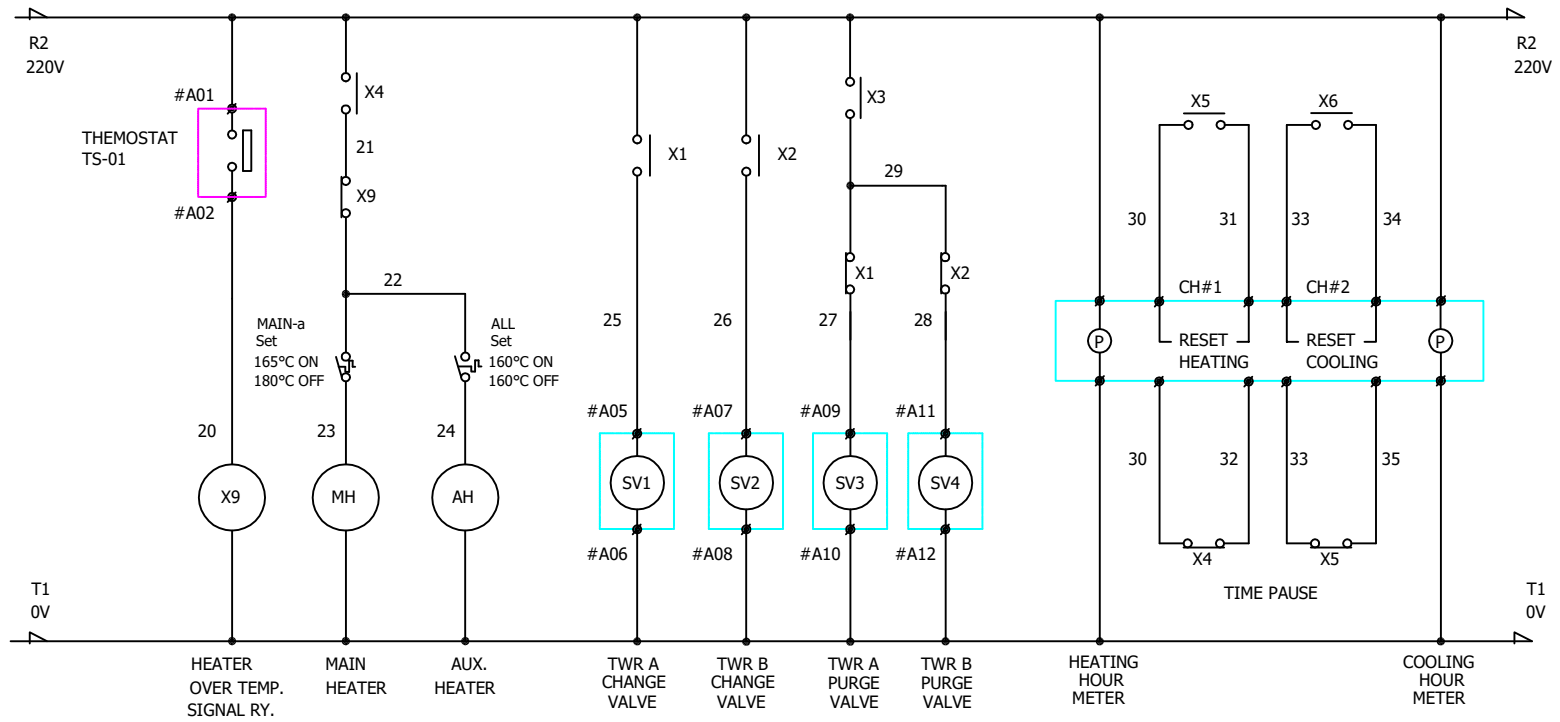

△										
△										
△										
△										
△	2018.12.10	ISSUED FOR PROPOSAL	-	-	-	-	-	-	-	
REV.	DATE	DESCRIPTION	ENGR	CHK	APPD	APPD	APPD	APPD	APPD	
PROJECT										
MANUFACTURER										
TITLE										
PEH-1550 WIRING										
ITEM NO.	PEH-1550	DWG NO.								REV.
SCALE	NONE	GSA-PEH-1550-06							△	