	Refrigerated Air Dryer		Rev.	Date	Prepared By	Checked By	Approved By
			A	2019.01.15	LEE.S.M.	JO.S.J.	KIM.H.W.
	Air Cooled Type		B				
			C				
			D				
Project Name		-	Model Name		HYD-50N		
SPECIFICATION							
1							
2	Supply Voltage	220V	Inlet Flow Rate	6.7	Nm3/min		
3	Phase	1PH	Inlet Pressure	7	barg		
4	Frequency	60Hz	Inlet Temp.	38	°C		
5	Control use	220V	Outlet Flow Rate	6.7	Nm3/min		
6	Fulid	Compressed Air	Outlet Pressure	6.8	barg		
7	Location	Indoor	Outlet Temp.	28±5	°C		
8	Design Code	Maker STD.	Pressure Drop	0.2	bar		
9	Area Class	Non-Hazardous	Outlet Dew Point	2~10	°C		
10			Design Pressure	14	barg		
11			Design Temperature	70	°C		
12			Ambient Temperature	32	°C		
CONSTRUCTION							
13							
14	Refrigerant	R-22	Dimension (W x L x H)	404 X 704 X 952	mm		
15	Ref. Compressor Type	Rotary	Weight	89	kg		
16	Ref. Compressor Capacity	1 HP	Power Consumption	1.4	kW		
17	Condenser Type	Air Cooled	Inlet Connection	40A	PT Female Screw		
18	Condenser Fan Motor	100 W	Outlet Connection	40A	PT Female Screw		
19		1 EA	Drain Connection	15A	PT Female Screw		
20	Condenser Fan Size	350 mm	Color (Munsell)	5.7PB 4.1/9.9			
21	Condenser Capacity	1 HP		5.7PB 2.9/3.5			
22	Condenser Material	Aluminum & Copper					
23	Heat Exchanger Type	Block					
24	Heat Exchanger Material	Aluminum					
25	Ref. Control Device	Capillary Tube					
26	Temp. Control Device	Hot Gas Bypass Valve					
27	Drain Trap Type	Auto Float					
STANDRAD FEATURES AND CONTROL							
28							
29	Fan Control Switch	YES	Ref. Compressor	YES			
30	Ref. Liquid Filter Dryer	YES	Capillary Tube	YES			
31	Overload Relay	NO	Hot Gas Bypass Valve	YES			
32	PCB Controller	YES	Air Cooled Condenser	YES			
33	Fan Motor Test Button	NO	Accumulator	NO			
34	Air Pressure Gauge	NO	Liquid Ref. Receiver	NO			
35	Ref. Pressure Gauge	NO	Oil Separator	NO			
36	High Pressure Switch	YES	Circuit Breaker	NO			
37	Moisture Indicator	NO	Ref. Compressor Heater	NO			
38	Drain	YES					
NOTES							
39							
40							
41							
42							
43							
44							
45							
46							

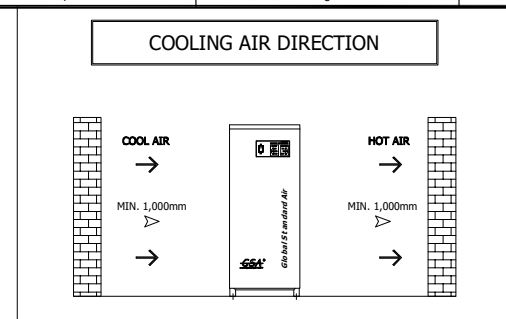

SPECIFICATION	
INLET AIR TEMPERATURE	38°C
AMBIENT TEMPERATURE	32°C
INLET AIR PRESSURE	7 barg
CAPACITY	6.7 Nm ³ /min
IN/OUT CONNECTION	PT 40A
DIMENSION(WXDXH, mm)	404 X 704 X 952
WEIGHT	89 kg
POWER CONSUMPTION	1.41 kW
POWER SUPPLY	220/380/440V - 1PH - 50/60Hz

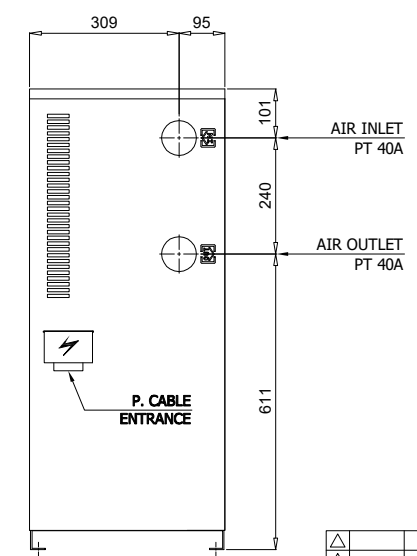
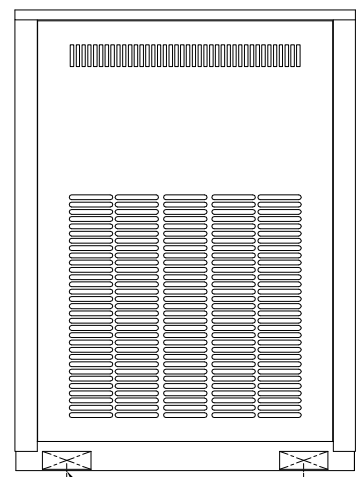
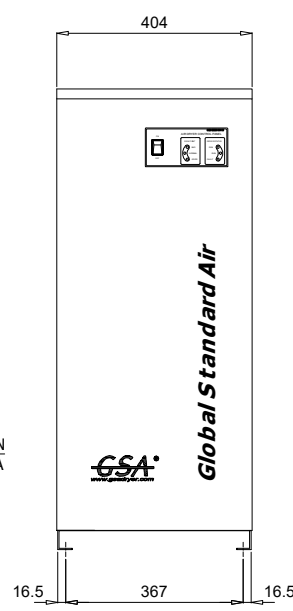
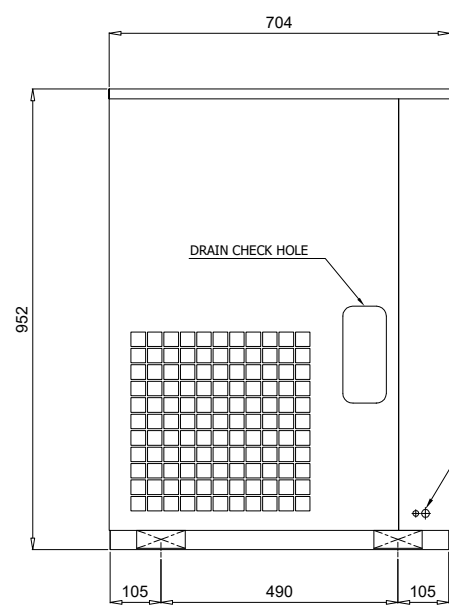
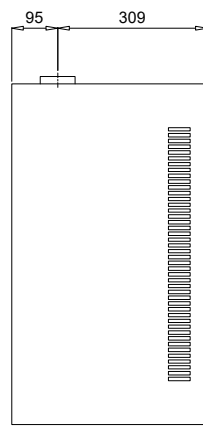

△									
△									
△									
△									
△	2020. 03. 20.	CHANGE OF CONTROL PCB							
△	2018. 11. 26.	ISSUED FOR REFERENCE							
REV. NO.	DATE	DESCRIPTION	DWG.	CHK.	APPD.	APPD.	APPD.	APPD.	APPD.
PROJECT									
MANUFACTURER									
TITLE									
OUTLINE DRAWING									
ITEM NO.	HYD-SON	DWG NO.					REV.		
SCALE	NONE	GSA-HYD-0050N-01					△		

DEW POINT		2~10°C @ PDP	
INLET AIR PRESSURE		7.0 BARG	
INLET AIR TEMPERATURE		38°C	
CAPACITY		6.7 Nm ³ /min	
10	CAPILLARY TUBE	-	1
9	HGBV	-	1
8	AUTO DRAIN	IN : PT 15A / OUT : 6A	1
7	HEAT EXCHANGER	50 HP	1
6	FILTER DRYER	3/8"	1
5	HPS	24 BARG	1
4	FAN CONTROLLER	12 ~ 18 BARG	1
3	FAN MOTOR	0.1KW 4P φ350	1
2	A/C CONDENSER	1 HP (CONDENSING CAPACITY)	1
1	REF. COMPRESSOR	1 HP (COOLING CAPACITY)	1
NO.	PART NAME	DESCRIPTION	QTY

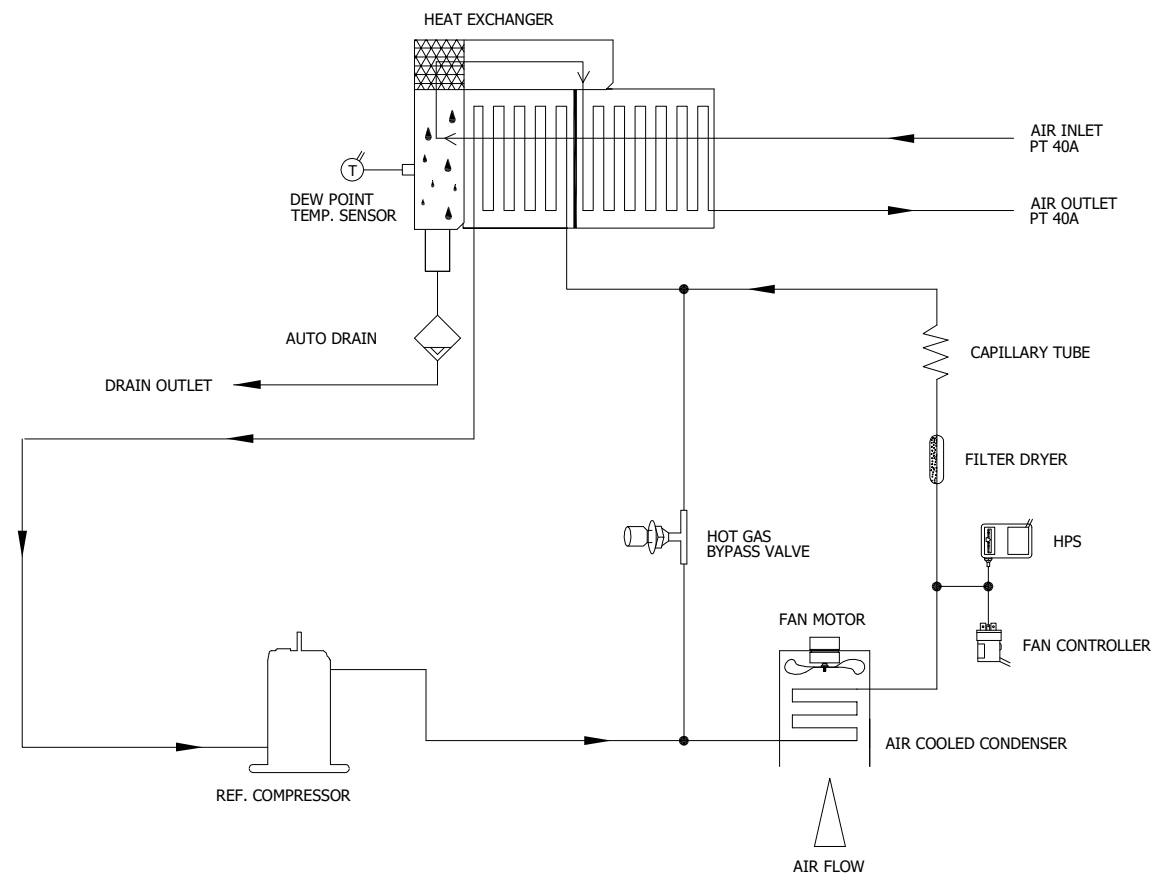

- ← AIR INLET LINE
- AIR OUTLET LINE
- ← REF. LOW PRESS. LINE
- REF. HIGH PRESS. LINE

△									
△									
△									
△									
△	2020. 09. 16.	PARTS NUMBER DELETE							
△	2018. 11. 26.	ISSUED FOR REFERENCE							
REV. NO.	DATE	DESCRIPTION	DWG	CHK	APPD	APPD	APPD	APPD	APPD
PROJECT									
MANUFACTURER									
									
TITLE									
PIPING & INSTRUMENTATION DRAWING									
ITEM NO.	HYD-SON	DWG NO.	REV.						
SCALE	NONE	GSA-HYD-0050N-02	△						

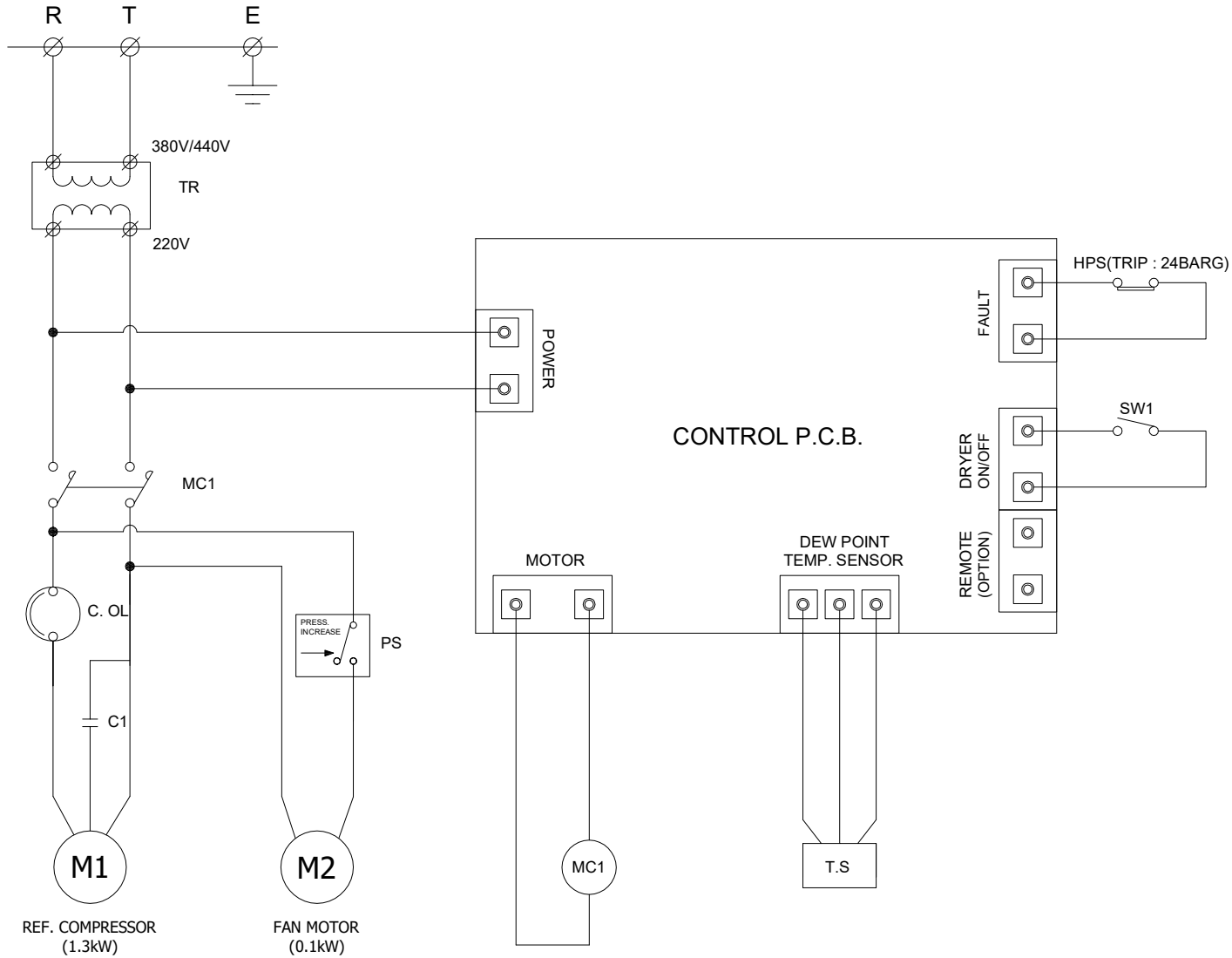

POWER SOURCE AC 220/380/440V, 1Ph, 50/60Hz		
10	SW1	SYSTEM ON/OFF SWITCH
9	C. OL	REF. COMPRESSOR OVERLOAD
8	HPS	HIGH PRESSURE SWITCH
7	T.S	DEW POINT TEMP. SENSOR
6	TR	TRANSFORMER(OPTION)
5	MC1	MAGNETIC CONTACTOR
4	PS	FAN CONTROLLER
3	C1	RUNNING CAPACITOR
2	M2	FAN MOTOR
1	M1	REF. COMPRESSOR
NO.	SYMBOL	DESCRIPTION

△									
△									
△									
△									
△									
△	2018. 11. 26.	ISSUED FOR REFERENCE							

REV. NO.	DATE	DESCRIPTION	DWG.	CHK.	APPD.	APPD.
PROJECT						

MANUFACTURER



TITLE

WIRING DRAWING

ITEM NO.	HYD-SO	DWG NO.	REV.
SCALE	NONE	GSA-HYD-0050N-03	△