	Refrigerated Air Dryer		Rev.	Date	Prepared By	Checked By	Approved By
			A	2019.01.15	LEE.S.M.	JO.S.J.	KIM.H.W.
	Air Cooled Type		B				
			C				
D							
Project Name			-		Model Name		HYD-500N
SPECIFICATION							
1							
2	Supply Voltage	380V	Inlet Flow Rate	66	Nm3/min		
3	Phase	3PH	Inlet Pressure	7	barg		
4	Frequency	60Hz	Inlet Temp.	38	°C		
5	Control use	220V	Outlet Flow Rate	66	Nm3/min		
6	Fulid	Compressed Air	Outlet Pressure	6.8	barg		
7	Location	Indoor	Outlet Temp.	28±5	°C		
8	Design Code	Maker STD.	Pressure Drop	0.2	bar		
9	Area Class	Non-Hazardous	Outlet Dew Point	2~10	°C		
10			Design Pressure	9.7	barg		
11			Design Temperature	70	°C		
12			Ambient Temperature	32	°C		
CONSTRUCTION							
13							
14	Refrigerant	R-22	Dimension (W x L x H)	1200 X 1800 X 1825	mm		
15	Ref. Compressor Type	Scroll	Weight	940	kg		
16	Ref. Compressor Capacity	13 HP	Power Consumption	11.7	kW		
17	Condenser Type	Air Cooled	Inlet Connection	150A	KS 10K SO.FF.		
18	Condenser Fan Motor	0.4 kW	Outlet Connection	150A	KS 10K SO.FF.		
19		2 EA	Drain Connection	15A	PT Female Screw		
20	Condenser Fan Size	600 mm	Color (Munsell)	5.7PB 4.1/9.9			
21	Condenser Capacity	15 HP		5.7PB 2.9/3.5			
22	Condenser Material	Aluminum & Copper					
23	Heat Exchanger Type	Block					
24	Heat Exchanger Material	Aluminum					
25	Ref. Control Device	TEV					
26	Temp. Control Device	Hot Gas Bypass Valve					
27	Drain Trap Type	Level Sensor					
STANDRAD FEATURES AND CONTROL							
28							
29	Ref. Pressure Transmitter	YES	Ref. Compressor	YES			
30	Ref. Liquid Filter Dryer	YES	Expansion Valve	YES			
31	Overload Relay	YES	Hot Gas Bypass Valve	YES			
32	PCB Controller	YES	Air Cooled Condenser	YES			
33	4.3" TFT LCD	YES	Accumulator with Heat Exchanger	YES			
34	Air Pressure Gauge	YES	Liquid Ref. Receiver	NO			
35	Ref. Pressure Gauge	YES	Oil Separator	YES			
36	Dual Pressure Switch	NO	Circuit Breaker	YES			
37	Moisture Indicator	YES	Ref. Compressor Heater	YES			
38	Drain	YES					
NOTES							
39							
40							
41							
42							
43							
44							
45							
46							

AIR INLET
150A KS 10K SO.FF.

AIR OUTLET
150A KS 10K SO.FF.

COOLING AIR DIRECTION

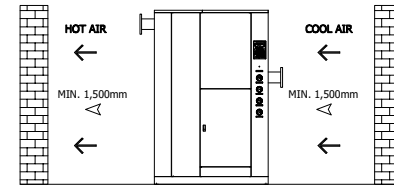

SPECIFICATION	
INLET AIR TEMPERATURE	38°C
AMBIENT TEMPERATURE	32°C
INLET AIR PRESSURE	7 barg
CAPACITY	66.0 Nm ³ /min
IN/OUT CONNECTION	150A KS 10K SO.FF.
DIMENSION(WXDXH, mm)	1,200 X 1,800 X 1,830
WEIGHT	940 kg
POWER CONSUMPTION	12.9 kW
POWER SUPPLY	380/440V - 3PH - 50/60HZ

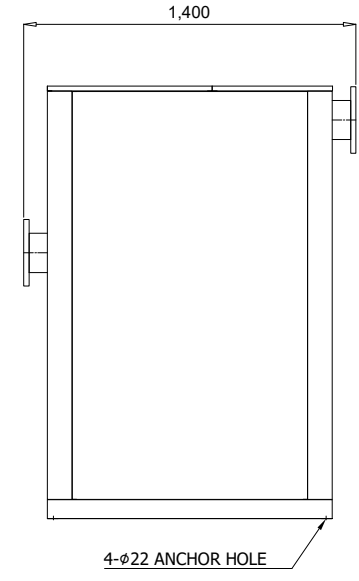
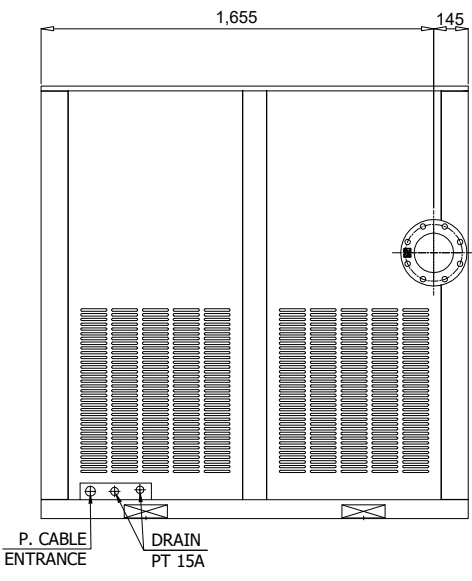
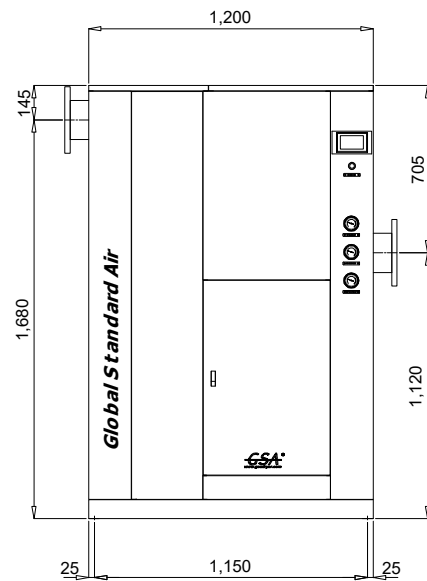
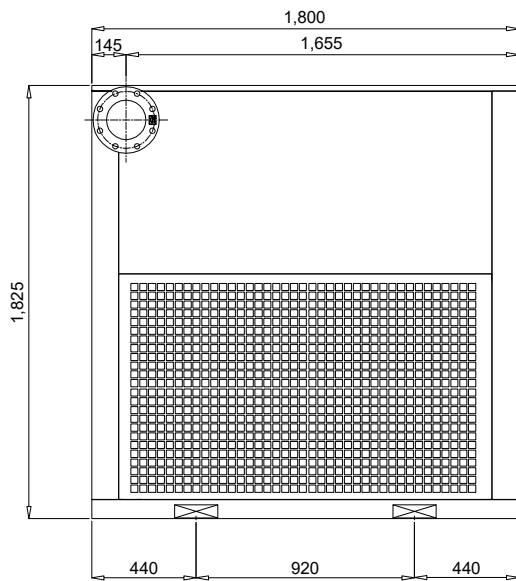

△									
△									
△									
△									
△									
△	2018. 11. 26.	ISSUED FOR REFERENCE							
REV. NO.	DATE	DESCRIPTION	DWG. CHK.	APPD.	APPD.	APPD.			
PROJECT									
MANUFACTURER									
 GSA <small>Global Standard Air & Gas</small>									
TITLE									
OUTLINE DRAWING									
ITEM NO.	HYD-500N	DWG NO.	GSA-HYD-0500N-01						
SCALE	NONE								REV. △

DEW POINT	2~10°C @ PDP		
INLET AIR PRESSURE	7.0 BARG		
INLET AIR TEMPERATURE	38°C		
CAPACITY	66.0 Nm ³ /min		
15	PRESS. GAUGE	OUTLET AIR	1
14	PRESS. GAUGE	INLET AIR	1
13	PRESS. GAUGE	REF. SUCTION	1
12	AUTO DRAIN	PT 15A	1
11	HGBV	-	1
10	HEAT EXCHANGER	300 HP	2
9	EXPANSION VALVE	7.5 TON	2
8	MOIST. INDICATOR	5/8"	1
7	FILTER DRYER	5/8"	1
6	ACCUMULATOR WITH HEAT EXCHANGER	-	1
5	REF. PRESS. TRANSMIT.	-1 ~ 35 BAR	1
4	FAN MOTOR	0.4KW 6P ø600	2
3	A/C CONDENSER	15 HP (CONDENSING CAPACITY)	1
2	OIL SEPARATOR	-	1
1	REF. COMPRESSOR	13 HP (COOLING CAPACITY)	1
NO.	PART NAME	DESCRIPTION	QTY

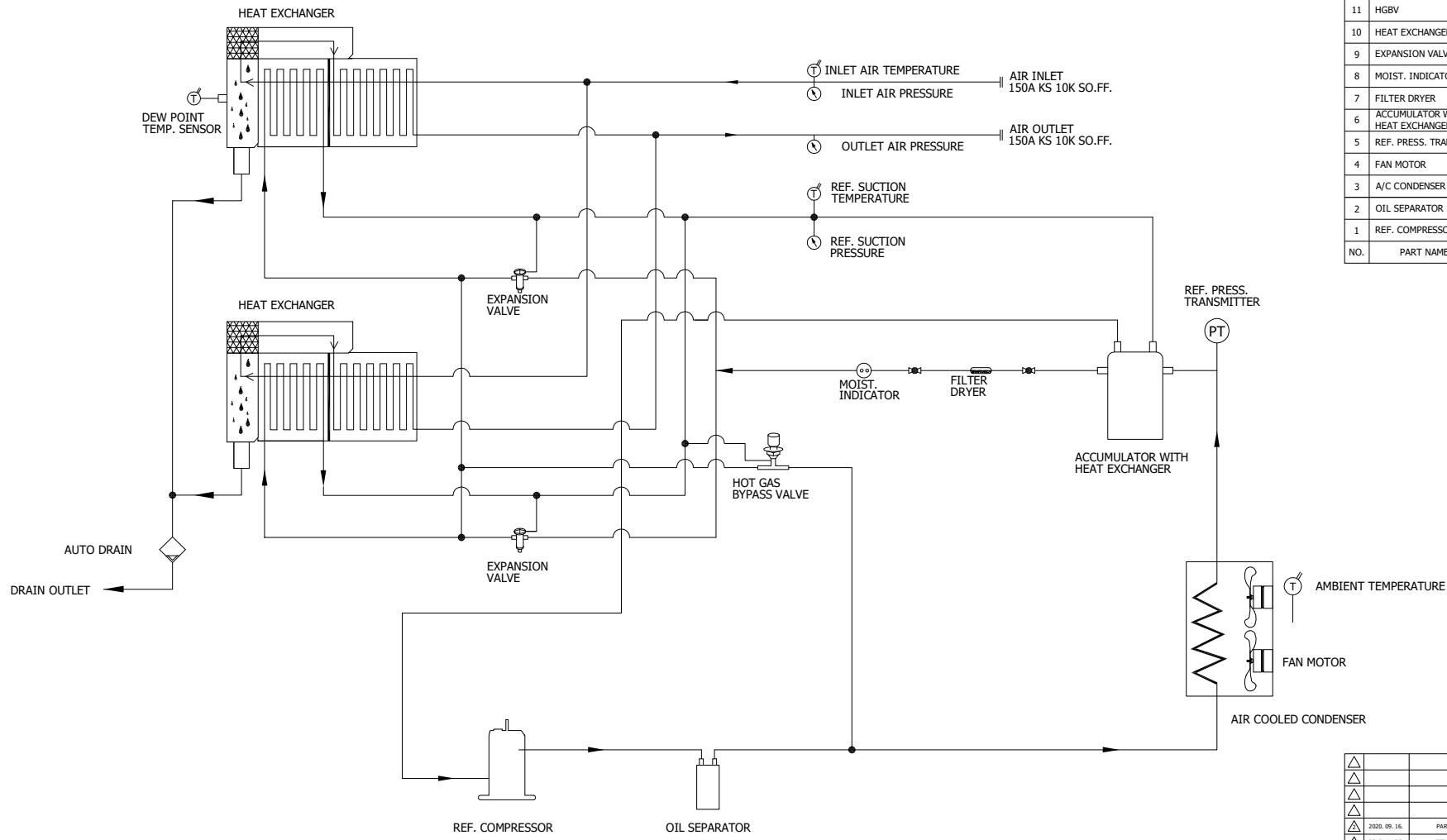

- ← AIR INLET LINE
- AIR OUTLET LINE
- ← REF. LOW PRESS. LINE
- REF. HIGH PRESS. LINE

△										
△										
△										
△										
△	2020. 09. 16.	PARTS NUMBER DELETE								
△	2018. 11. 26.	ISSUED FOR REFERENCE								
REV. NO.	DATE	DESCRIPTION	ENG.	CHK.	APPD.	APPD.	APPD.			
PROJECT										
MANUFACTURER										
										
TITLE										
PIPING & INSTRUMENTATION DRAWING										
ITEM NO.	HYD-500N	DWG NO.	GSA-HYD-0500N-02				REV.	△		
SCALE	NONE									

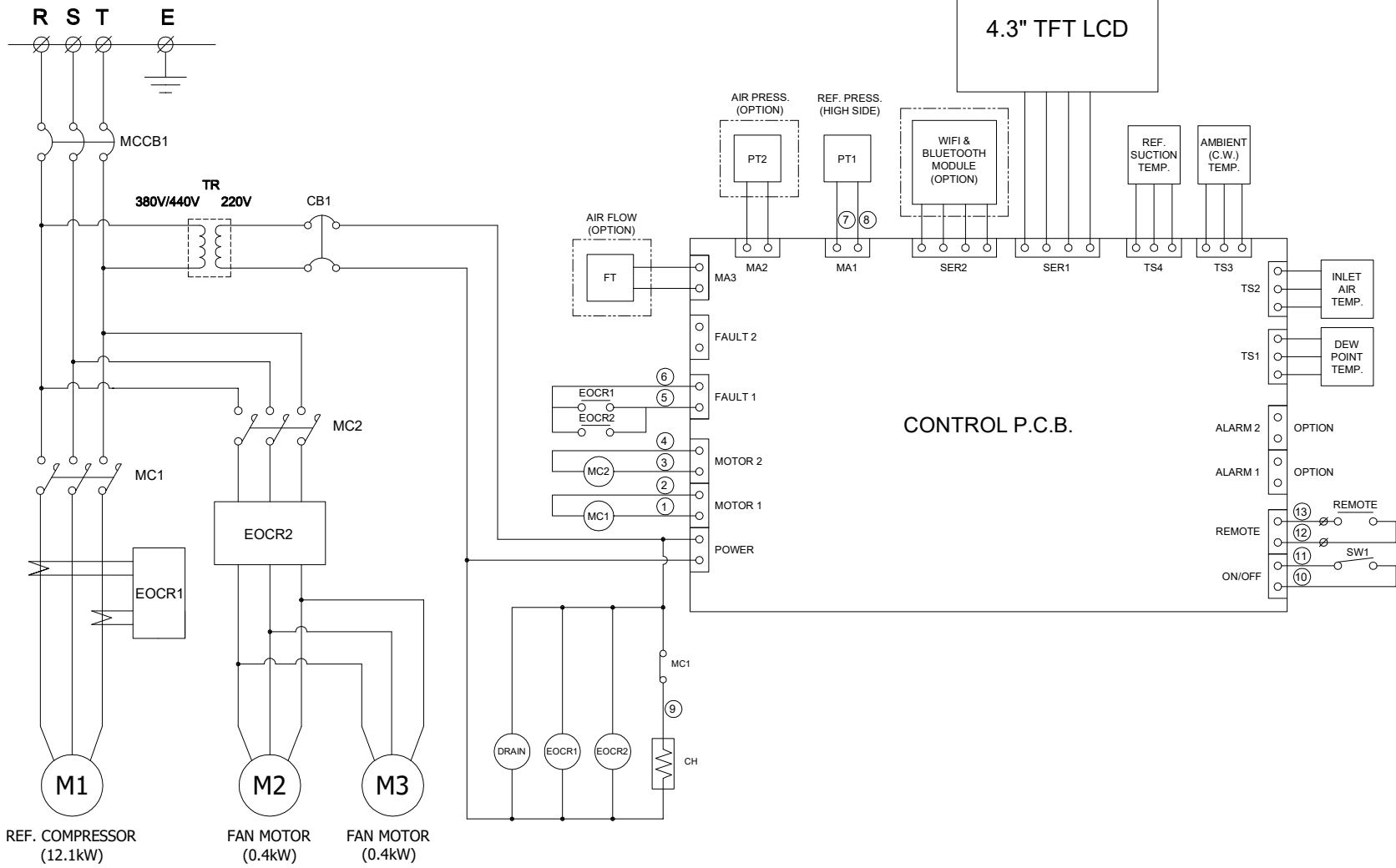

POWER SOURCE AC 380/440V, 3Ph, 50/60Hz		
12	MA1 ~ MA3	PRESSURE & FLOW SENSOR
11	DRAIN	AUTO DRAIN VALVE
10	SW1	SYSTEM ON/OFF SWITCH
9	C.H.	REF. COMP. HEATER
8	DRAIN	AUTO DRAIN VALVE
7	TS1 ~ TS4	TEMP. SENSOR
6	CB1	CIRCUIT BREAKER(CTRL)
5	MCCB1	CIRCUIT BREAKER(MAIN)
4	MC1, MC2	MAGNETIC CONTACTOR
3	EOCR1, EOCR2	OVERLOAD RELAY
2	M2, M3	FAN MOTOR
1	M1	REF. COMPRESSOR
NO.	SYMBOL	DESCRIPTION

***REVERSE PHASE WARNING**

Be sure to check the rotation direction of the fan motor and the operating condition of the refrigerant compressor.

- The fan motor must rotate clockwise.
- When the refrigerant compressor is operating, the refrigerant suction pressure will be lowered.

When operating in reverse phase, the refrigerant compressor is damaged.

In case of reverse phase, change the position of 2 wires out of 3 wires of the power supply line.

Problems caused by incorrect power connection are not guaranteed.

△									
△									
△									
△									
△									
△	2018. 11. 26.	ISSUED FOR REFERENCE							
REV. NO.	DATE	DESCRIPTION	DWG	CHK	APPD	APPD	APPD	APPD	APPD
PROJECT									

MANUFACTURER

GSA
Global Service Air & Gas

TITLE

WIRING DRAWING

ITEM NO.	HYD-500N	DWG NO.	GSA-HYD-0500N-03	REV.	△
SCALE	NONE				

(A4 : 297mm x 210mm)