	<b>Refrigerated Air Dryer</b>		Rev.	Date	Prepared By	Checked By	Approved By
			A	2019.01.15	LEE.S.M.	JO.S.J.	KIM.H.W.
	<b>Air Cooled Type</b>		B				
			C				
			D				
Project Name		-	Model Name		HYD-100N		
<b>SPECIFICATION</b>							
1							
2	Supply Voltage	380V	Inlet Flow Rate	14.2	Nm <sup>3</sup> /min		
3	Phase	3PH	Inlet Pressure	7	barg		
4	Frequency	60Hz	Inlet Temp.	38	°C		
5	Control use	220V	Outlet Flow Rate	14.2	Nm <sup>3</sup> /min		
6	Fulid	Compressed Air	Outlet Pressure	6.8	barg		
7	Location	Indoor	Outlet Temp.	28±5	°C		
8	Design Code	Maker STD.	Pressure Drop	0.2	bar		
9	Area Class	Non-Hazardous	Outlet Dew Point	2~10	°C		
10			Design Pressure	14	barg		
11			Design Temperature	70	°C		
12			Ambient Temperature	32	°C		
<b>CONSTRUCTION</b>							
13							
14	Refrigerant	R-22	Dimension (W x L x H)	454 X 794 X 1045	mm		
15	Ref. Compressor Type	Recipro Hemertic	Weight	126	kg		
16	Ref. Compressor Capacity	2 HP	Power Consumption	2.3	kW		
17	Condenser Type	Air Cooled	Inlet Connection	50A	PT Female Screw		
18	Condenser Fan Motor	0.2 kW	Outlet Connection	50A	PT Female Screw		
19		1 EA	Drain Connection	15A	PT Female Screw		
20	Condenser Fan Size	450 mm	Color (Munsell)	5.7PB 4.1/9.9			
21	Condenser Capacity	2 HP		5.7PB 2.9/3.5			
22	Condenser Material	Aluminum & Copper					
23	Heat Exchanger Type	Block					
24	Heat Exchanger Material	Aluminum					
25	Ref. Control Device	Capillary Tube					
26	Temp. Control Device	Hot Gas Bypass Valve					
27	Drain Trap Type	Auto Float					
<b>STANDRAD FEATURES AND CONTROL</b>							
28							
29	Fan Control Switch	YES	Ref. Compressor	YES			
30	Ref. Liquid Filter Dryer	YES	Capillary Tube	YES			
31	Overload Relay	NO	Hot Gas Bypass Valve	YES			
32	PCB Controller	YES	Air Cooled Condenser	YES			
33	Fan Motor Test Button	NO	Accumulator	NO			
34	Air Pressure Gauge	NO	Liquid Ref. Receiver	NO			
35	Ref. Pressure Gauge	NO	Oil Separator	NO			
36	High Pressure Switch	YES	Circuit Breaker	NO			
37	Moisture Indicator	NO	Ref. Compressor Heater	NO			
38	Drain	YES					
<b>NOTES</b>							
39							
40							
41							
42							
43							
44							
45							
46							

SPECIFICATION

INLET AIR TEMPERATURE	38°C
AMBIENT TEMPERATURE	32°C
INLET AIR PRESSURE	7 barg
CAPACITY	14.2 Nm <sup>3</sup> /min
IN/OUT CONNECTION	PT 50A
DIMENSION(WXDXH, mm)	458 X 858 X 1,145
WEIGHT	126 kg
POWER CONSUMPTION	2.41 kW
POWER SUPPLY	380/440V - 3PH - 50/60Hz

COOLING AIR DIRECTION

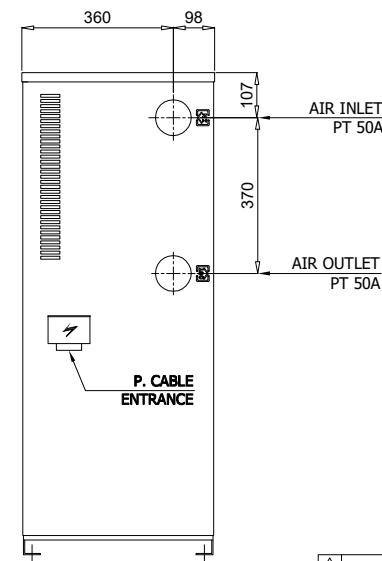
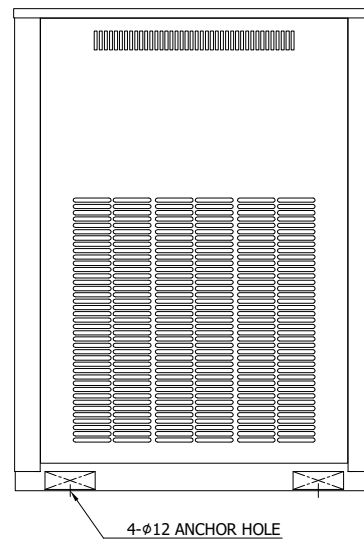
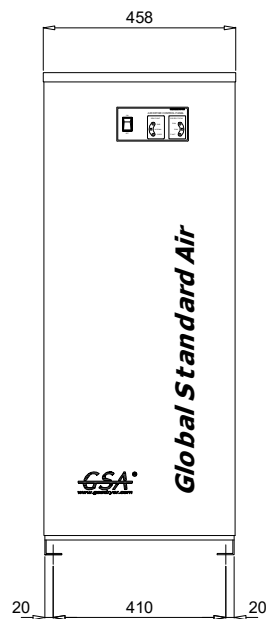
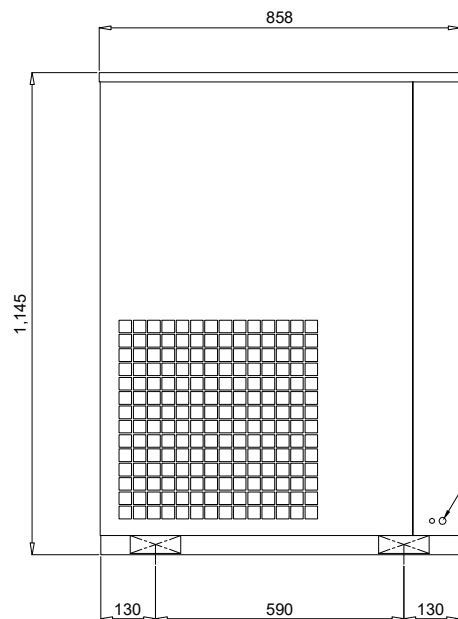
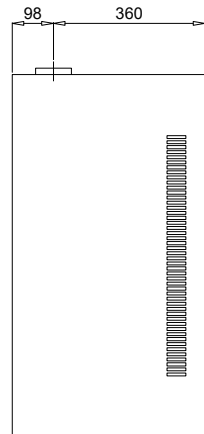
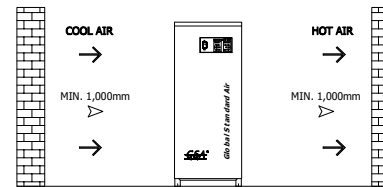

△									
△									
△									
△									
△	2020. 03. 20.	CHANGE OF CONTROL PCB							
△	2018. 11. 26.	ISSUED FOR REFERENCE							
REV. NO.	DATE	DESCRIPTION	DWG	CHK	APPD	APPD	APPD		
PROJECT									
MANUFACTURER									
TITLE									
OUTLINE DRAWING									
ITEM NO.	HYD-100N	DWG NO.	GSA-HYD-0100N-01				REV.		
SCALE	NONE								

DEW POINT		2~10°C @ PDP	
INLET AIR PRESSURE		7.0 BARG	
INLET AIR TEMPERATURE		38°C	
CAPACITY		14.2 Nm <sup>3</sup> /min	
10	CAPILLARY TUBE	-	1
9	HGBV	-	1
8	AUTO DRAIN	IN : PT 15A / OUT : 6A	1
7	HEAT EXCHANGER	100 HP	1
6	FILTER DRYER	3/8"	1
5	HPS	24 BARG	1
4	FAN CONTROLLER	12 ~ 18 BARG	1
3	FAN MOTOR	0.2KW 6P φ450	1
2	A/C CONDENSER	2 HP (CONDENSING CAPACITY)	1
1	REF. COMPRESSOR	2 HP (COOLING CAPACITY)	1
NO.	PART NAME	DESCRIPTION	QTY

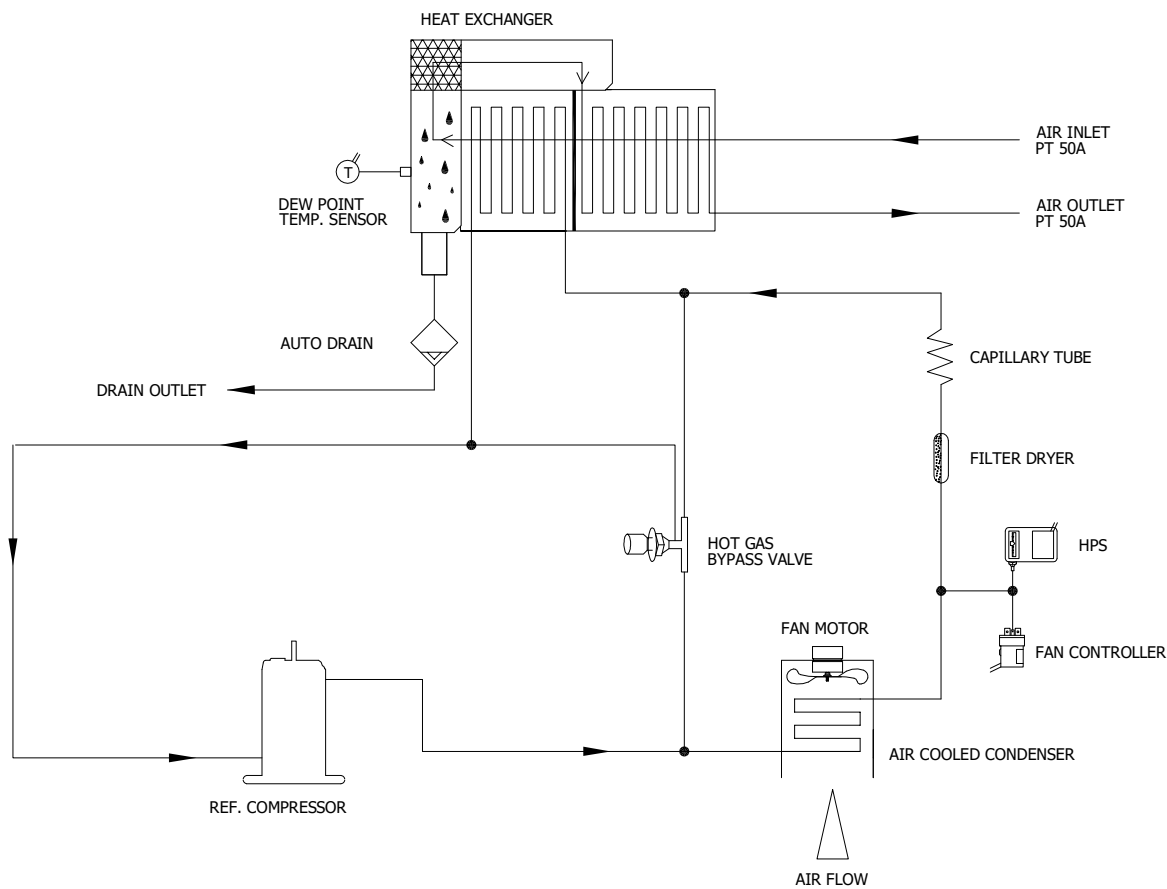

- ← AIR INLET LINE
- AIR OUTLET LINE
- ← REF. LOW PRESS. LINE
- REF. HIGH PRESS. LINE

△										
△										
△										
△										
△	2020. 09. 16.	PARTS NUMBER DELETE								
△	2018. 11. 26.	ISSUED FOR REFERENCE								
REV. NO.	DATE	DESCRIPTION	DWG	CHK	APPD	APPD	APPD			
PROJECT										
MANUFACTURER										
										
TITLE										
PIPING & INSTRUMENTATION DRAWING										
ITEM NO.	HYD-100N	DWG NO.	GSA-HYD-0100N-02				REV.	△		
SCALE	NONE									

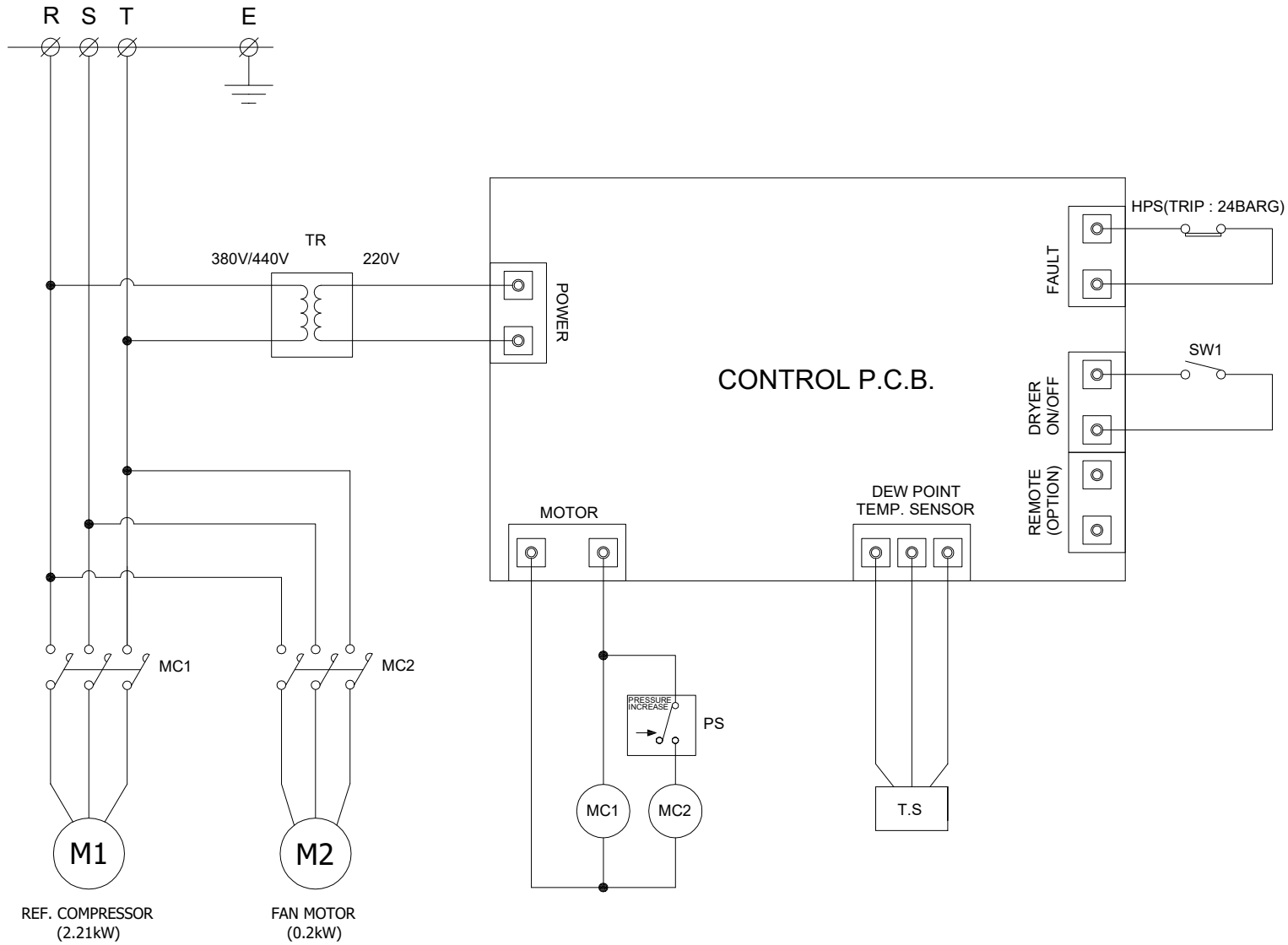

POWER SOURCE AC 380/440V, 3Ph, 50/60Hz		
9	SW1	SYSTEM ON/OFF SWITCH
8	HPS	HIGH PRESSURE SWITCH
7	T.S	DEW POINT TEMP. SENSOR
6	TR	TRANSFORMER(OPTION)
5	MC1, 2	MAGNETIC CONTACTOR
4	PS	FAN CONTROLLER
3	C1	RUNNING CAPACITOR
2	M2	FAN MOTOR
1	M1	REF. COMPRESSOR
NO.	SYMBOL	DESCRIPTION

△										
△										
△										
△										
△										
△	2018. 11. 26.	ISSUED FOR REFERENCE								
REV. NO.	DATE	DESCRIPTION	DWG	CHK	APPD	APPD	APPD	APPD	APPD	
PROJECT										
MANUFACTURER										
										
TITLE										
WIRING DRAWING										
ITEM NO.	HYD-100N	DWG NO.	GSA-HYD-0100N-03				REV.	△		
SCALE	NONE									